

# USER'S MANUAL

## ICO150

Robust Din-rail Fanless Embedded  
System

User's Manual



[www.axiomtek.com](http://www.axiomtek.com)

## **Disclaimers**

This manual has been carefully checked and believed to contain accurate information. Axiomtek Co., Ltd. assumes no responsibility for any infringements of patents or any third party's rights, and any liability arising from such use.

Axiomtek does not warrant or assume any legal liability or responsibility for the accuracy, completeness or usefulness of any information in this document. Axiomtek does not make any commitment to update the information in this manual.

Axiomtek reserves the right to change or revise this document and/or product at any time without notice.

No part of this document may be reproduced, stored in a retrieval system, or transmitted, in any form or by any means, electronic, mechanical, photocopying, recording, or otherwise, without the prior written permission of Axiomtek Co., Ltd.

**©Copyright 2026 Axiomtek Co., Ltd.**

**All Rights Reserved**

**March 2026, Version A1**

**Printed in Taiwan**

## Safety Precautions

Before getting started, please read the following important safety precautions.

1. The ICO150 does not come equipped with an operating system. An operating system must be loaded first before installing any software into the computer.
2. Be sure to ground yourself to prevent static charge when installing the internal components. Use a grounding wrist strap and place all electronic components in any static-shielded devices. Most electronic components are sensitive to static electrical charge.
3. Disconnect the power cord from the ICO150 before making any installation. Be sure both the system and the external devices are turned OFF. Sudden surge of power could ruin sensitive components. Make sure the ICO150 is properly grounded.
4. Make sure the voltage of the power source is correct before connecting the equipment to the power outlet.
5. Turn OFF the system power before cleaning. Clean the system using a cloth only. Do not spray any liquid cleaner directly onto the screen.
6. Do not leave this equipment in an uncontrolled environment where the storage temperature is below  $-45^{\circ}\text{C}$  or above  $85^{\circ}\text{C}$ . It may damage the equipment.
7. Do not open the system's back cover. If opening the cover for maintenance is a must, only a trained technician is allowed to do so. Integrated circuits on computer boards are sensitive to static electricity. To avoid damaging chips from electrostatic discharge, observe the following precautions:
  - Before handling a board or integrated circuit, touch an unpainted portion of the system unit chassis for a few seconds. This will help to discharge any static electricity on your body.
  - When handling boards and components, wear a wrist-grounding strap, available from most electronic component stores.
8. Caution  
Risk of explosion if battery is replaced by an incorrect type dispose of used batteries according to the instructions.
9. Warning  
Hot Surface Do NoT Touch.  
Restricted access area: The equipment should only be installed in a Restricted Access Area.
10. This product is intended to be supplied by a Listed Power Adapter or DC power source, output meets SELV, rated 12-24Vdc, minimum 2.538-1.256A, Tma = 70 degree C, and the altitude of operation = 2000m.  
If need further assistance with purchasing the power source, please contact to manufacturer for further information.

## **Classification**

1. Degree of protection against electric shock: not classified
2. Degree of protection against the ingress of water: IP30
3. Equipment not suitable for use in the presence of a flammable anesthetic mixture with air or with oxygen or nitrous oxide.
4. Mode of operation: Continuous
5. Type of protection against electric shock: Class I equipment

## **General Cleaning Tips**

You may need the following precautions before you begin to clean the computer. When you clean any single part or component for the computer, please read and understand the details below fully.

When you need to clean the device, please rub it with a piece of dry cloth.

1. Be cautious of the tiny removable components when you use a vacuum cleaner to absorb the dirt on the floor.
2. Turn the system off before you start to clean up the component or computer.
3. Never drop the components inside the computer or get circuit board damp or wet.
4. Be cautious of all kinds of cleaning solvents or chemicals when you use it for the sake of cleaning. Some individuals may be allergic to the ingredients.
5. Try not to put any food, drink or cigarette around the computer.

## Cleaning Tools

Although many companies have created products to help improve the process of cleaning your computer and peripherals users can also use household items to clean their computers and peripherals. Below is a listing of items you may need or want to use while cleaning your computer or computer peripherals.

Keep in mind that some components in your computer may only be able to be cleaned using a product designed for cleaning that component, if this is the case it will be mentioned in the cleaning.

- Cloth: A piece of cloth is the best tool to use when rubbing up a component. Although paper towels or tissues can be used on most hardware as well, we still recommend you rub it with a piece of cloth.
- Water or rubbing alcohol: You may moisten a piece of cloth a bit with some water or rubbing alcohol and rub it on the computer. Unknown solvents may be harmful to the plastics parts.
- Vacuum cleaner: Absorb the dust, dirt, hair, cigarette particles, and other particles out of a computer can be one of the best methods of cleaning a computer. Over time these items can restrict the airflow in a computer and cause circuitry to corrode.
- Cotton swabs: Cotton swabs moistened with rubbing alcohol or water are excellent tools for wiping hard to reach areas in your keyboard, mouse, and other locations.
- Foam swabs: Whenever possible it is better to use lint free swabs such as foam swabs.



**Note:** *We strongly recommended that you should shut down the system before you start to clean any single components.*

### **Please follow the steps below:**

1. Close all application programs
2. Close operating software
3. Turn off power
4. Remove all device
5. Pull out power cable

## **Scrap Computer Recycling**

If the computer equipments need the maintenance or are beyond repair, we strongly recommended that you should inform your Axiomtek distributor as soon as possible for the suitable solution. For the computers that are no longer useful or no longer working well, please contact your Axiomtek distributor for recycling and we will make the proper arrangement.

## **Trademarks Acknowledgments**

Axiomtek is a trademark of Axiomtek Co., Ltd. IBM, PC/AT, PS/2, VGA are trademarks of International Business Machines Corporation.

Intel<sup>®</sup> and Pentium<sup>®</sup> are registered trademarks of Intel Corporation.

MS-DOS, Microsoft C and QuickBASIC are trademarks of Microsoft Corporation.

VIA is a trademark of VIA Technologies, Inc.

SST is a trademark of Silicon Storage Technology, Inc.

UMC is a trademark of United Microelectronics Corporation. Other brand names and trademarks are the properties and registered brands of their respective owners.

# Table of Contents

---

Safety Precautions .....	iii
Classification .....	iv
General Cleaning Tips .....	iv
Scrap Computer Recycling .....	vi
<b>SECTION 1 INTRODUCTION .....</b>	<b>1</b>
<b>1.1 General Description .....</b>	<b>1</b>
<b>1.2 System Specifications .....</b>	<b>4</b>
1.2.1 CPU .....	4
1.2.2 BIOS .....	4
1.2.3 System Memory .....	4
1.2.4 Display .....	4
1.2.5 System Block diagram .....	5
1.2.6 Ethernet Ports .....	7
1.2.7 Storages .....	7
1.2.8 Extension .....	7
1.2.9 Placement .....	7
1.2.10 Connectors .....	9
1.2.11 COM/CAN .....	10
1.2.12 Digital I/O Connector and Pin Definition .....	11
1.2.13 Power .....	11
1.2.14 WatchDog Timer (WDT) .....	11
1.2.15 Restore BIOS Optimal Defaults (Clear CMOS) .....	11
1.2.16 System LED .....	12
1.2.17 Operation Temperature .....	12
1.2.18 Storage Temperature .....	12
1.2.19 Humidity .....	12
1.2.20 Weight .....	12
1.2.21 Dimensions (W x D x H) .....	12
1.3 Dimensions .....	13
1.4 I/O Outlets .....	15
<b>SECTION 2 HARDWARE INSTALLATION .....</b>	<b>17</b>
2.1 Installing the Memory Module .....	17
2.2 Install half-size mini card module .....	23
2.3 Installing Wireless Module .....	27
2.4 Installing NVMe Module .....	34
2.5 Installing Din-rail Mounting (Screw: M3 x 6 4pcs) .....	37
2.6 Installing the HDMI Bracket .....	38
<b>SECTION 3 AMI UEFI BIOS UTILITY .....</b>	<b>39</b>
3.1 Entering Setup .....	39
3.2 The Main Menu .....	39
3.3 Advanced Features .....	40
3.4 Chipset Feature .....	48
3.5 Security .....	49
3.6 Boot Type .....	51
3.7 Save & Exit .....	52
<b>APPENDIX A WATCHDOG TIMER .....</b>	<b>53</b>
About Watchdog Timer .....	53
How to Use Watchdog Timer .....	53

**This page is intentionally left blank.**

# SECTION 1

## INTRODUCTION

This chapter contains general information and detailed specifications of the ICO150. The Chapter 1 includes the following sections:

- General Description
- System Specification
- Dimensions
- I/O Outlets

### 1.1 General Description

ICO150 Din-rail fanless embedded system is suitable for communications control and for protocol converter applications in critical environments. Built for rugged work environments, ICO150 features an extra low power consumption Intel® Atom® X7433RE(1.5GHz) processors supporting industrial temperature range of -40°C to +70°C. Its front accessible I/O cabling is very convenient for wiring and maintenance. ICO150 offers a HDMI output, making it particularly well-suited for data acquisition, communication control, SCADA and industrial automation. Its compact size with Din-rail mounting allows for easy installation into control cabinet. Pre-installed (optional) with Linux, Windows® 10/11 IoT, ICO150 provides programmers with a friendly environment for developing application software at a lower cost.

ICO150 is robust industrial-grade hardware design, besides, supporting the mSATA, M.2 SSD which makes it especially suitable for field control & monitoring system solution for following markets:

Utility Industries (Water; Energy; Chemical Plant; Mining...)

Public Transportation Industries (Traffic/ Highway Control; Train/Bus Control...)

Homeland Security (Weather Monitoring/Alarm System...)

● **Checklist - AC**

- ✓ ICO150 System Unit x 1
- ✓ DDR thermal
  - \_ Thermal pad x2
  - \_ Therma BKT x1
- ✓ Half Size Mini Card
  - \_ thermal pad x2
  - \_ Therma BKT x1
- ✓ Full Size Mini Card
  - \_ thermal pad x1
  - \_ Therma BKT x1
- ✓ M.2 KeyB
  - \_ Therma pad x1
  - \_ Heat sink x1
  - \_ Extension brace x1
- ✓ Din-rail Kit x1
- ✓ Power 3 pin terminal block x 1
- ✓ HDMI BKT x1
- ✓ Cable Tie and Holding Kit for HDMI x1
- ✓ Screws for HDMI M3x4L x1(Black)
- ✓ Screws for M.2 M3x4L x2(Silver)
- ✓ Screws for Mini Card M2x5L x2(Silver)
- ✓ Screws for Mini Card/DDR
  - \_ M3x4L x2(Black)

● **Checklist - AW**

- ✓ ICO150 System Unit x 1
- ✓ DDR thermal
  - \_ THERMAL MODULE x1
  - \_ Thermal pad x4
  - \_ Heat sink x1
- ✓ Half Size Mini Card
  - \_ THERMAL MODULE x1
  - \_ Thermal pad x3
  - \_ Heat sink x1
- ✓ Full Size Mini Card
  - \_ Thermal pad x1
  - \_ Heat sink x1
- ✓ Full Size Mini Card
  - \_ Thermal pad x1
  - \_ Heat sink x1
- ✓ M.2 KeyB
  - \_ Therma pad x1
  - \_ Heat sink x1
  - \_ Extension brace x1
- ✓ Din-rail Kit x1
- ✓ Power 3 pin terminal block x 1
- ✓ HDMI BKT x1
- ✓ Cable Tie and Holding Kit for HDMI x1
- ✓ Screws M3x4L(Silver)
  - \_ DDR x2
  - \_ M.2 x2
  - \_ Half Size Mini Card x2
- ✓ Screws M3x4L x1(Black)
- ✓ Screws for Mini Card M2x5L x2(Silver)



**Note:** Please contact your local vendors if any damaged or missing items.

---

- **Features - AC**

- Fanless Design
- Wide temperature operation of 0°C - +50°C
- 1 x HDMI (1.4b, 4K); (2nd HDMI w/ FHD by option)
- 2 x 2.5Gb Ethernets with Magnetic Isolated Protection
- 4 x COM Ports support RS-232/422/485 with (DB9 Port)
- 2 x CAN Ports(by option)
- 1 x DIO (8-bit programmable DIO)
- 2 x USB 2.0
- 2 x USB 3.2 Gen1
- 1 x Half-Size PCI Express Mini Card slot with SATA or PCIe signal (mini mSATA or Wi-Fi)
- 1 x Full-Size PCI Express Mini Card slot (USB signal) with SIM slot for 4G-LTE module
- 1 x M.2 Bkey 2242 with PCIe signal (for B+M NVMe)
- TPM 2.0
- Watchdog Timer (255 levels, 1 to 255 sec)
- 1 x terminal block, 9 to 36 VDC, typical 12/24V
- Din-rail mounting
- Passed CE / FCC testing

- **Features - AW**

- Fanless Design
- Wide temperature operation of -40°C - +70°C
- 1 x HDMI (1.4b, 4K); (2nd HDMI w/ FHD by option)
- 2 x 2.5Gb Ethernets with Magnetic Isolated Protection
- 4 x COM Ports support RS-232/422/485 with (DB9 Port)
- 2 x CAN Ports(by option)
- 1 x DIO (8-bit programmable DIO)
- 2 x USB 2.0
- 2 x USB 3.2 Gen1
- 1 x Half-Size PCI Express Mini Card slot with SATA or PCIe signal (mini mSATA or Wi-Fi)
- 1 x Full-Size PCI Express Mini Card slot (USB signal) with SIM slot for 4G-LTE module
- 1 x M.2 B key 2242 with PCIe signal (for B+M NVMe)
- TPM 2.0
- Watchdog Timer (255 levels, 1 to 255 sec)
- 1 x terminal block, 9 to 36 VDC, typical 12/24V
- Din-rail mounting
- Passed CE / FCC testing.

- **Embedded O.S. Supported**
  - ICO150 not only supports Windows<sup>®</sup> 10/11, but also supports embedded OS, such as Windows<sup>®</sup> 10/11 IoT and Linux package support. For storage device, ICO150 supports one M.2 B key 2242 for B+M NVMe, one mini mSATA.

## 1.2 System Specifications

### 1.2.1 CPU

- Onboard Intel<sup>®</sup> Atom<sup>®</sup> X7433RE (1.5GHz)

### 1.2.2 BIOS

- AMI (American Megatrends Inc.) UEFI (Unified Extensible Firmware Interface) BIOS.

### 1.2.3 System Memory

- One DDR5-4800 262P SO-DIMM slot.
- Supports 4800 MHz up to 16GB.

### 1.2.4 Display

- 1 x HDMI 1.4b(up to 3840 x 2160 @30H)
- 1 x HDMI 1.4b(up to 1920 x 1080 @60Hz by option)

## 1.2.5 System Block diagram

### ICO150-AC

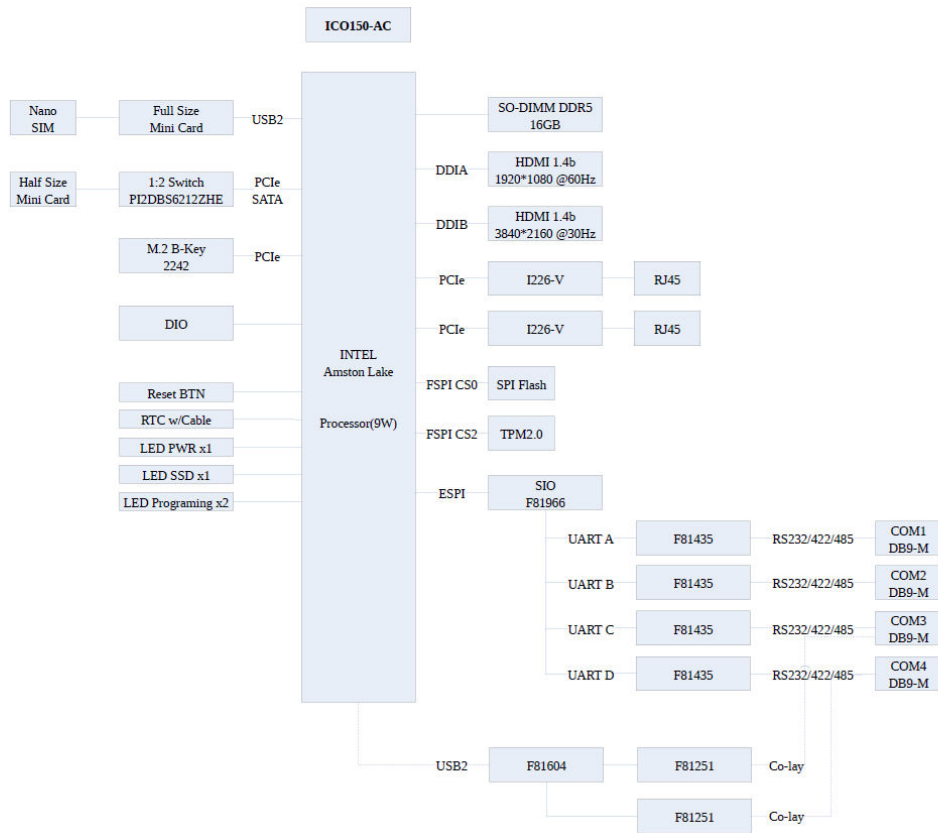

ICO150-AW

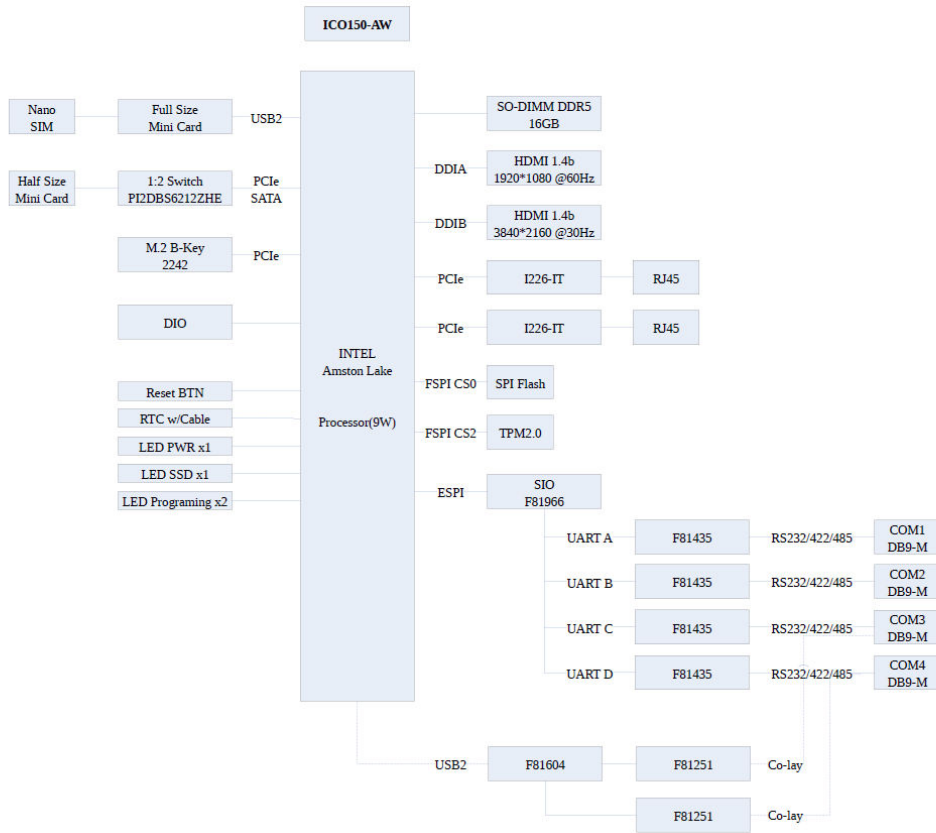

### 1.2.6 Ethernet Ports

- AC - LAN Chip: Intel Ethernet Controller I226-V.
- AW - LAN Chip: Intel Ethernet Controller I226-IT.
- LAN1~2 support 100/1000/2500 Base-T with 1.5KV magnetic isolated protection.

### 1.2.7 Storages

- 1 x M.2 B key 2242 for B+M NVMe.
- 1 x mini mSATA.

### 1.2.8 Extension

- 1 x half-size PCI Express Mini Card slot with SATA or PCIe signal (mini mSATA or Wi-Fi).
- 1 x full-size PCI Express Mini Card slot (USB signal) with SIM slot for 4G-LTE module.
- 1 x M.2 B key 2242 with PCIe signal (for B+M NVMe)
- 1 x SIM Card Socket (one for full size mini card).
- 4 x Antenna holes.

### 1.2.9 Placement

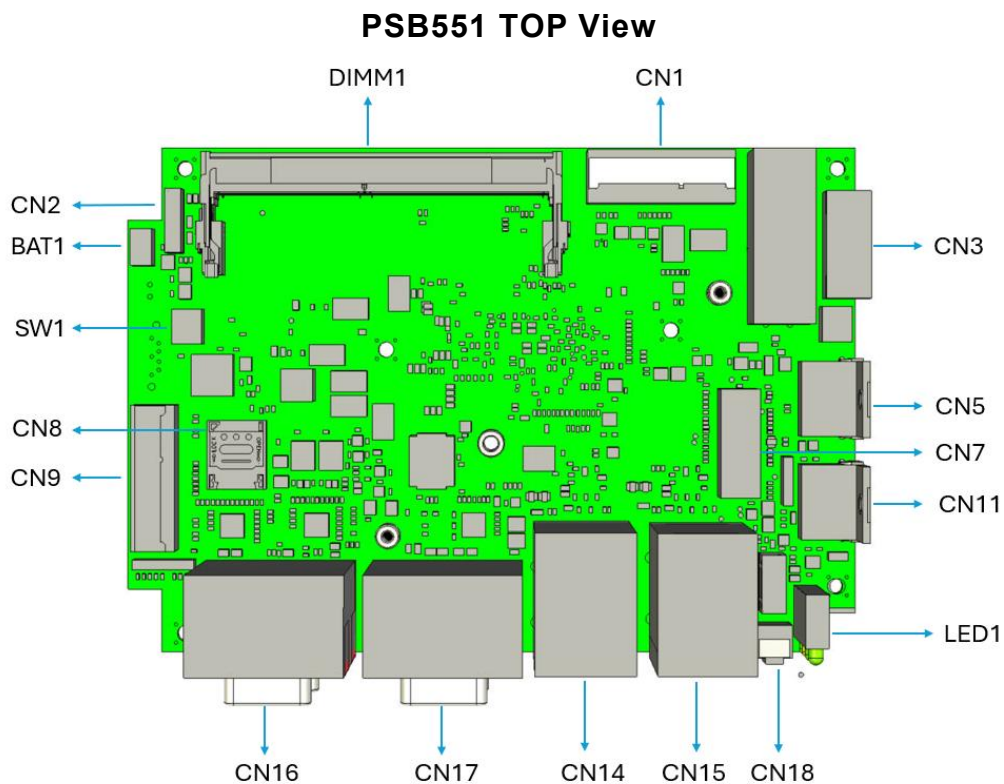

### PSB551 Bottom View

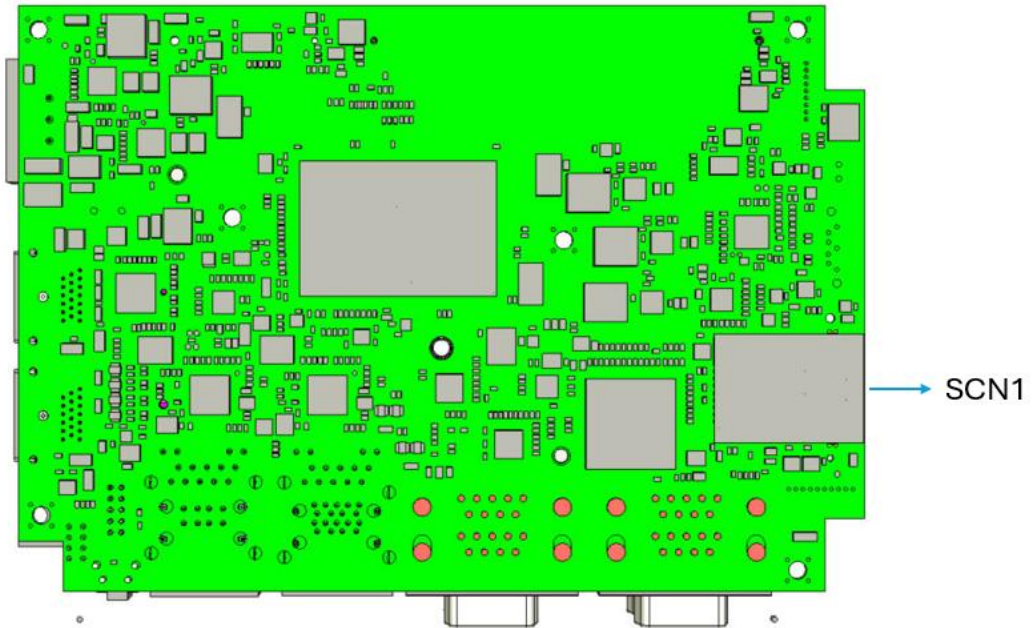

### 1.2.10 Connectors

Signals go to other parts of the system through connectors. Loose or improper connection might cause problems, please make sure all connectors are properly and firmly connected. Here is a summary table which shows all connectors on the hardware.

#### PSB551

Connectors	Label
DDR5 SODIMM Socket	DIMM1
3 pin terminal block for Power Input	CN3
HDMI output Connector	CN5
HDMI output Connector(option)	CN11
DIO Connector	CN2
USB3.2 Gen1 *2 Connector	CN18
Tact switch for clear CMOS	SW1
Battery Connector	BAT1
PWR/ACT/Programable	LED1
Mini Card Solt PCIe / mSATA interface)	CN1
M.2 B-key 2242 For NVMe(PCIe interface)	CN7
Nano SIM card slot	CN8
Mini Card Solt1(USB2.0 interface)	CN9
LAN connector/USB2.0	CN14
LAN connector/USB3.2 Gen1	CN15
COM1~2 Port with RS232 / RS422 /RS485	CN16
COM3~4 Port with RS232 / RS422 /RS485 (option CAN Ports)	CN17
SIM Card Slot(by option)	SCN1

### 1.2.11 COM/CAN

- 4 ports terminal block support RS-232/422/485 which can be selected by BIOS.
- Supports Auto Flow Control in RS485 mode.
- Serial Port Pin Define:

#### COM1~4

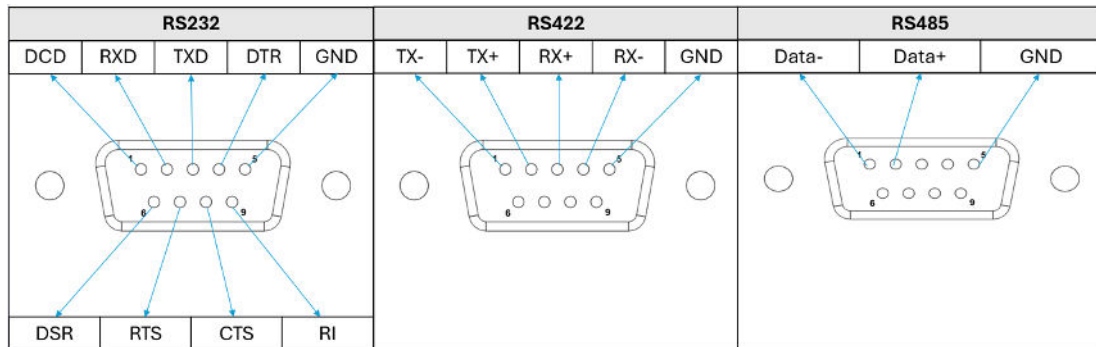

#### COM3~4(Option CAN)

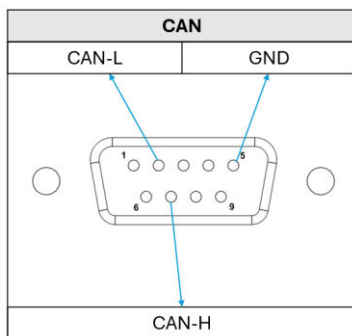

### 1.2.12 Digital I/O Connector and Pin Definition

- Side DB9 female connector supports 8 bits TTL level programmable digital input/output
- The voltage of TTL is 5V
- The programming is as follows:
  - I/O sink current is 8~10mA
  - Input/Output can be programmed

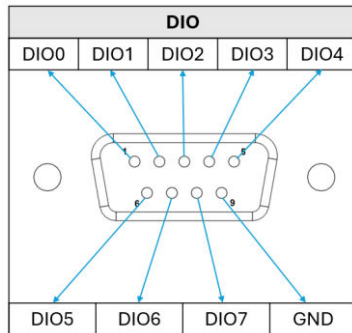

### 1.2.13 Power

- Wide-range 12 - 24V DC power input with terminal block.

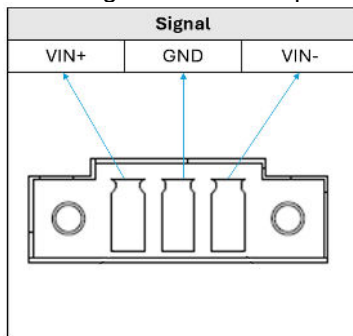

### 1.2.14 WatchDog Timer (WDT)

- 1~255 seconds or minutes; up to 255 levels.

### 1.2.15 Restore BIOS Optimal Defaults (Clear CMOS)

- Press the tact switch (10 seconds) can restore BIOS optimal defaults.

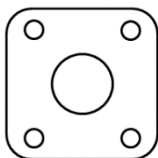

### 1.2.16 System LED

- There are showed the LED's indicators and functional descriptions.

LED Name	Description	Color
ACT	Indicate the storage status and it's flashing when storage access.	Green
PWR	Indicate the Power status. When the DC input is acceptable, the LED will ON.	Yellow
Programable LED	A sample code will be provided that allows users to define their own function (LED P1~P2).	Green

### 1.2.17 Operation Temperature

- Standard: 0°C ~ +50°C
- Industrial: -40°C ~ +70°C

### 1.2.18 Storage Temperature

- -40°C ~ +85°C

### 1.2.19 Humidity

- 10% ~ 95% (non-condensation)

### 1.2.20 Weight

- AC: 0.8kg
- AW: 1.5kg

### 1.2.21 Dimensions (W x D x H)

- AC: 48 x 110 x 155 mm (1.89" x 4.33" x 6.1")
- AW: 65 x 110 x 155 mm (2.56" x 4.33" x 6.1")





## 1.4 I/O Outlets

The following figures show you I/O outlets on front view and top view of the ICO150.

**ICO150-AC**

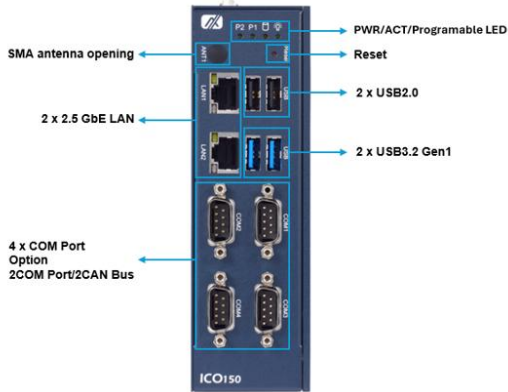

**ICO150-AW**

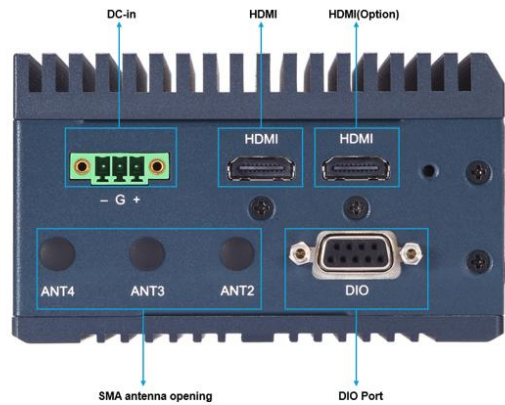
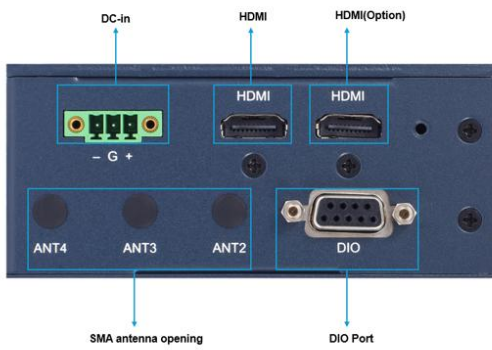
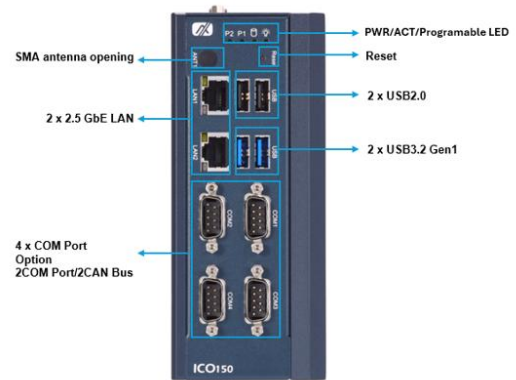

**This page is intentionally left blank.**

## SECTION 2 HARDWARE INSTALLATION

The ICO150 is convenient for your various hardware configurations, such as Memory Module and Hard Disk Drive. The chapter 2 will show you how to install the hardware. It includes:

### 2.1 Installing the Memory Module

#### AC

**Step 1** Turn off the system.

**Step 2** Loosen all screws of the cover and remove the cover from the system.

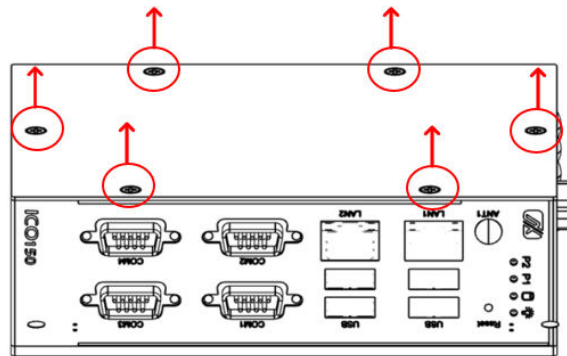

**Step 3** Put the thermal pad on the memory module to improve cooling effect.

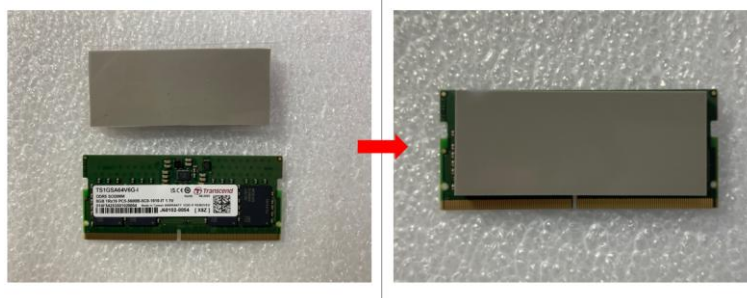

**Step 4** Use two fingers to hold the memory module and insert the gold figure into the slot and push the module down.

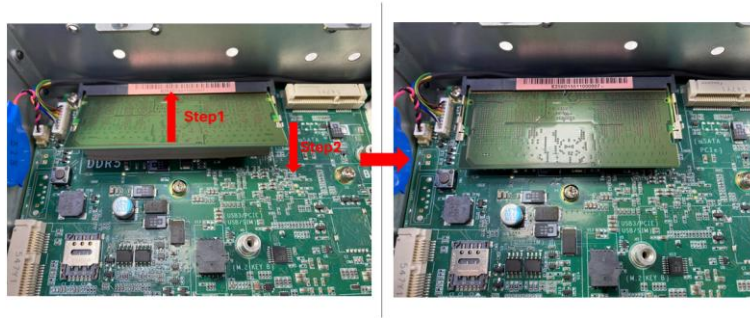

**Step 5** The memory module is locked by two latches on the sides. We strongly recommend using “LDC737” silicone on the two sides of the memory for good ability of vibration.



**Step 6** Apply the thermal pad to the memory module.

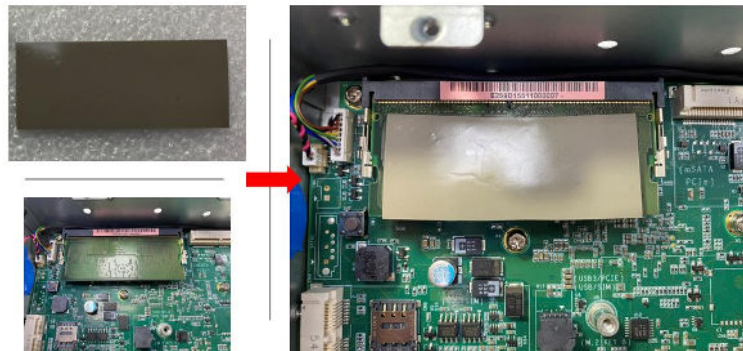

**Step 7 Install memory module thermal bracket.**

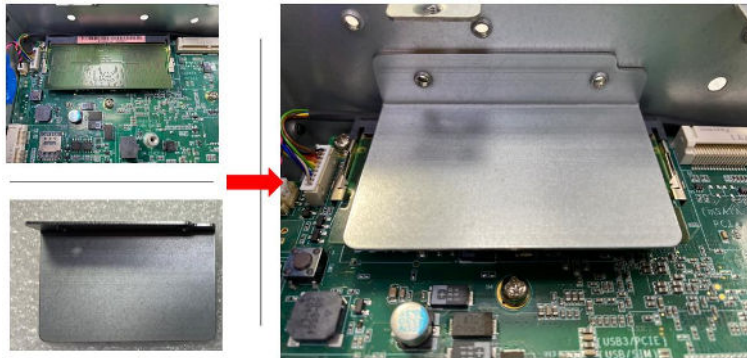

**Step 8 Tighten the bracket screws.**

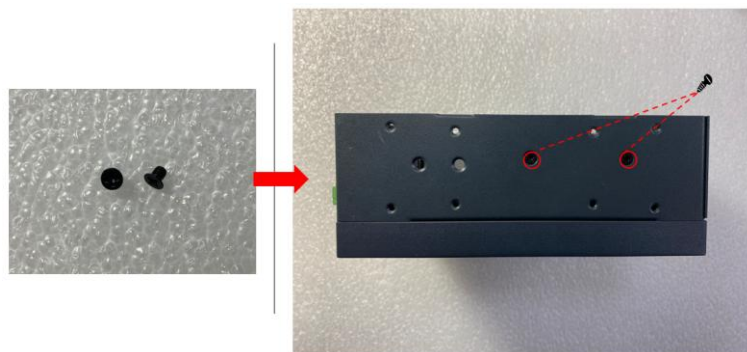

**Step 9 Put the cover back to the system and fasten screws tight close the chassis.**

**AW**

**Step 1** Turn off the system.

**Step 2** Loosen all screws of the cover and remove the cover from the system.

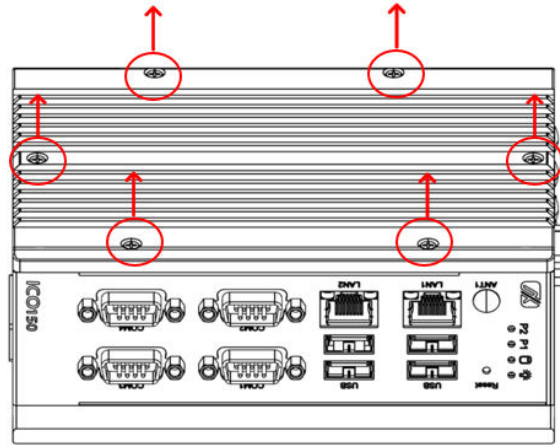

**Step 3** Apply thermal pad to the PCBA.

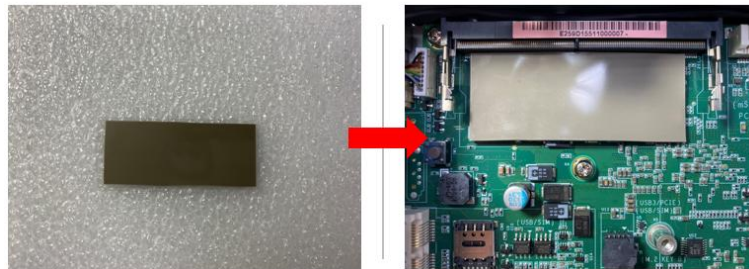

**Step 4** Assemble the memory thermal module.

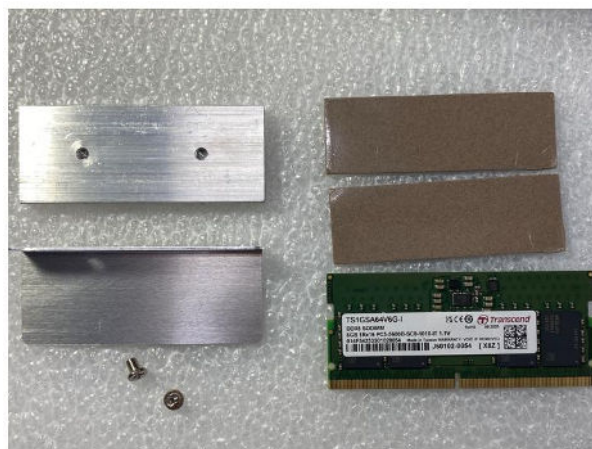

• Step1



• Step2



• Step3



• Step4



• Step5



**Step 5** Use two fingers to hold the memory module and insert the gold figure into the slot and push the module down.

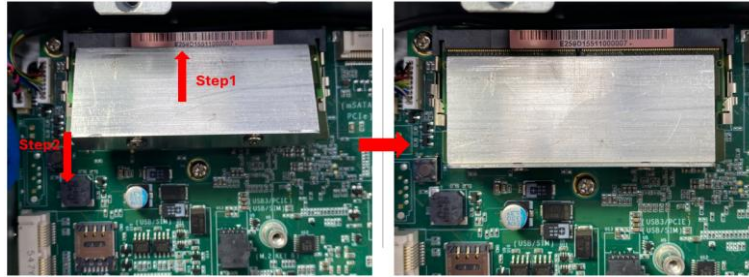

**Step 6** The memory module is locked by two latches on the sides. We strongly recommend using “LDC737” silicone on the two sides of the memory for good ability of vibration.



**Step 7** Adhesive memory module heatsink fins.

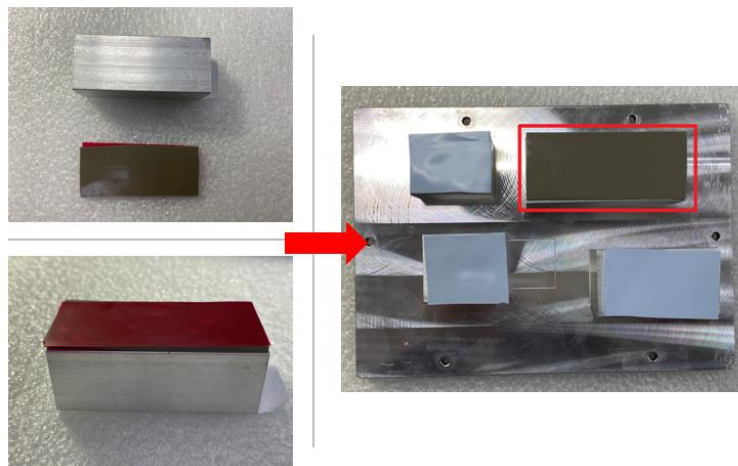

**Step 8** Put the cover back to the system and fasten screws tight close the chassis.

## 2.2 Install half-size mini card module.

### AC

Step 1 Turn off the system.

Step 2 Loosen all screws of the cover and remove the cover from the system.

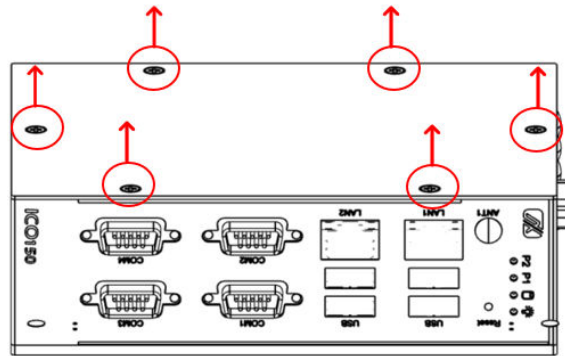

Step 3 Apply thermal pad to the PCBA

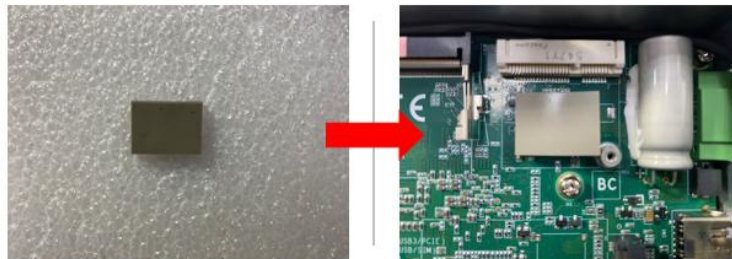

Step 4 Insert the mini card into the slot which marking with “mSATA / PCIe ” and fasten screws.



**Step 5 Install mini Card thermal pad and bracket.**

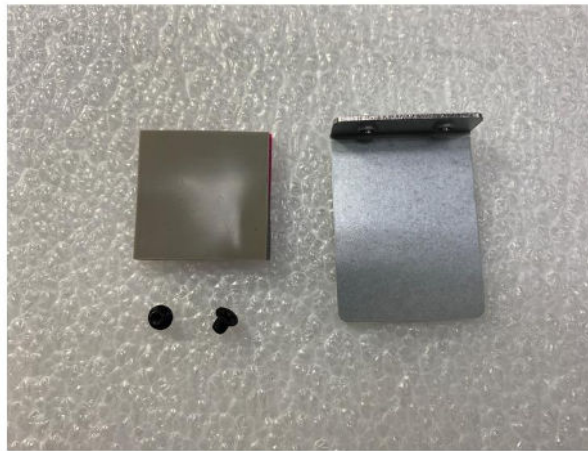

• Step1



• Step2



• Step3

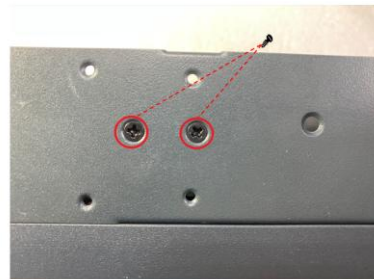

**Step 6 Put the cover back to the system and fasten screws tight close the chassis.**

**AW**

**Step 1** Turn off the system.

**Step 2** Loosen all screws of the cover and remove the cover from the system.

**Slim Mode**

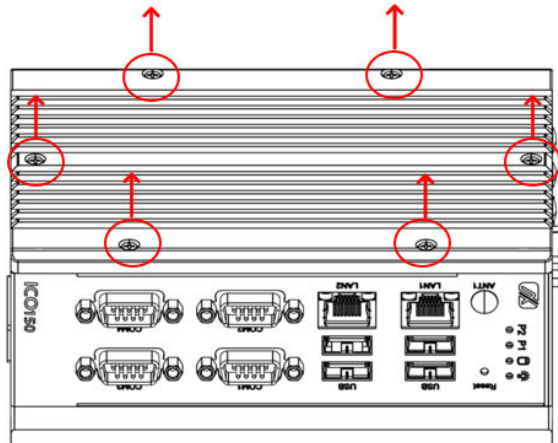

**Step 3** Apply thermal pad to the PCBA



**Step 4** Assemble the mini card thermal module.

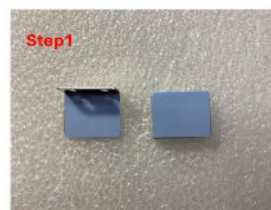

**Step 5** Insert the mini card into the slot which marking with “mSATA / PCIe ” and fasten screws.

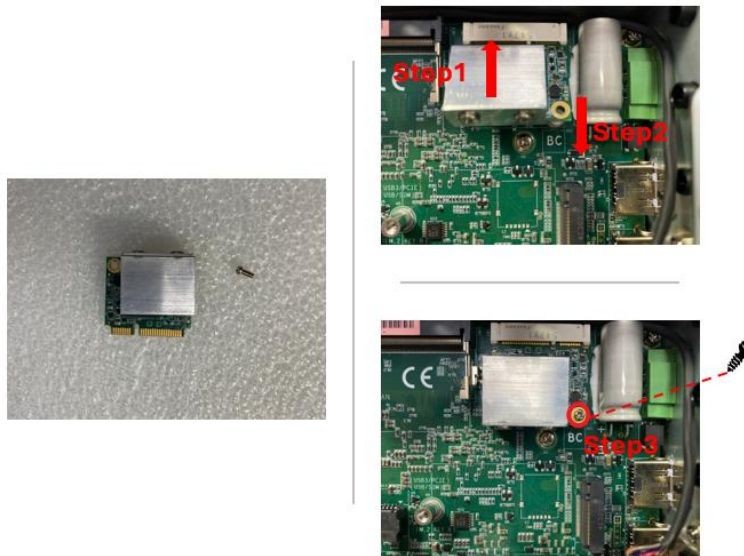

**Step 6** Adhesive mini card thermal pad and heatsink fins.

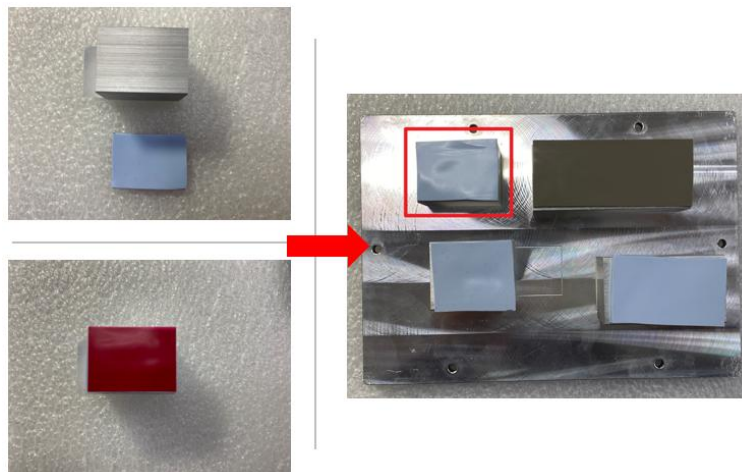

**Step 7** Put the cover back to the system and fasten screws tight close the chassis.

## 2.3 Installing Wireless Module

### AC

**Step 1** Turn off the system.

**Step 2** Loosen all screws of the cover and remove the cover from the system.

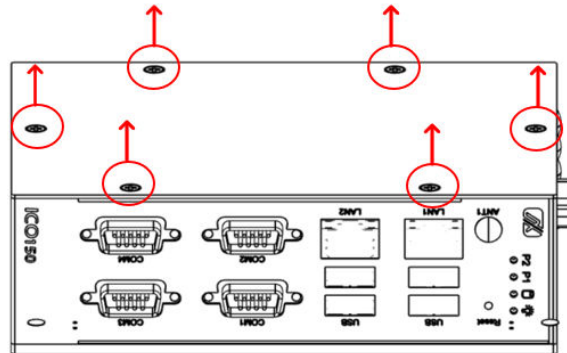

**Step 3** Following push the SIM slot back to unlock SIM slot, inserting the SIM card and put it back, and lock the SIM slot.

• Step1



• Step2



• Step3



• Step4



**Step 4** Insert the wireless module and screws it tight.



**Step 5 Apply the wireless module thermal pad.**

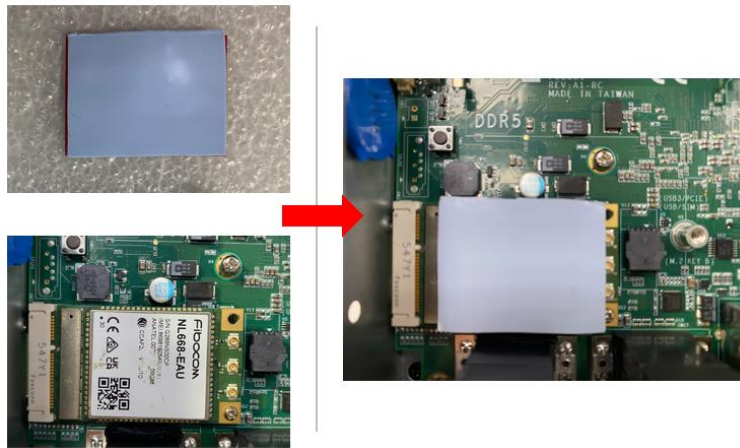

**Step 6 Install wireless module bracket and tighten the screws.**

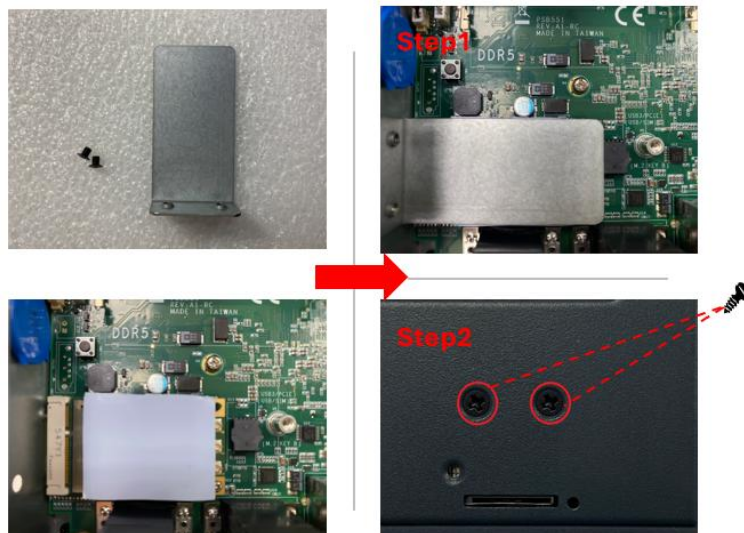

**Step 7 Install SIM card bracket and tighten the screws (by option).**

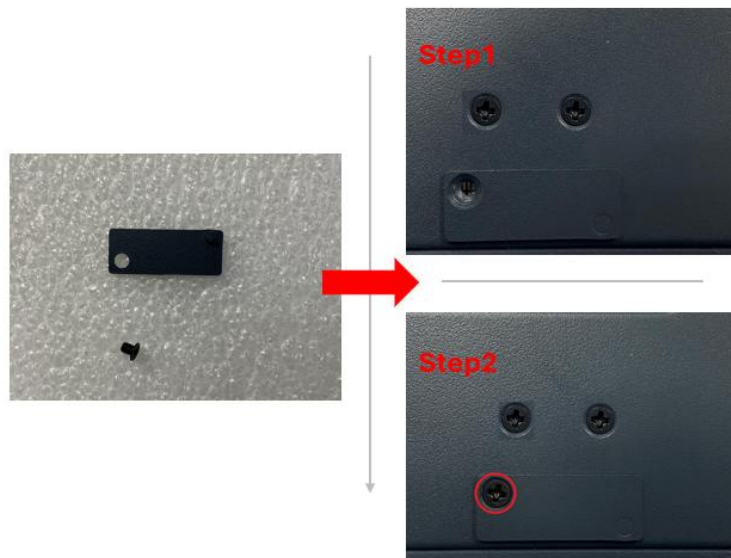

**Step 8 Put the cover back to the system and fasten screws tightly close the chassis.**

## AW

**Step 1 Turn off the system.**

**Step 2 Loosen all screws of the cover and remove the cover from the system.**

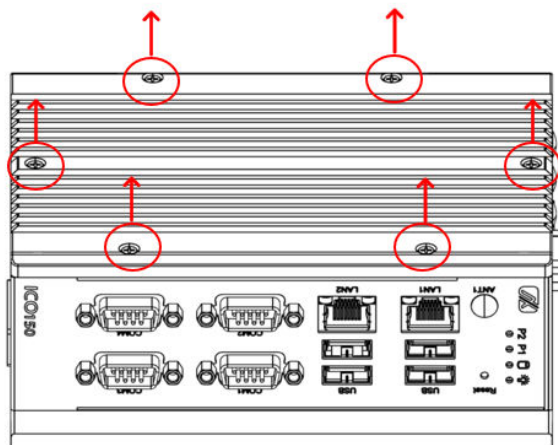

**Step 3** Following push the SIM slot back to unlock SIM slot, inserting the SIM card and put it back, and lock the SIM slot.

• Step1



• Step2



• Step3



• Step4



**Step 4 Insert the wireless module and screws it tight.**

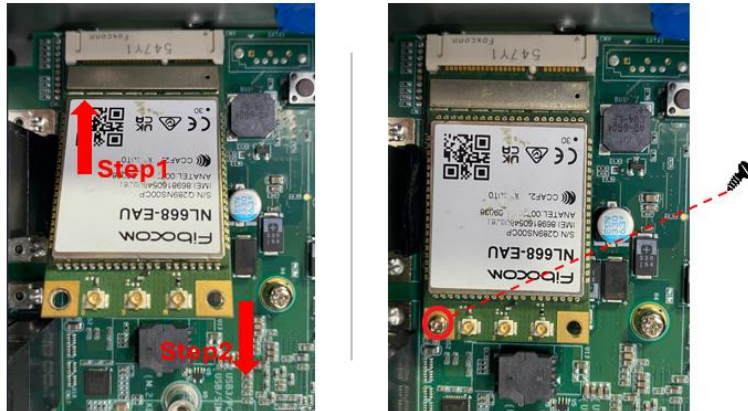

**Step 5 Adhesive wireless module thermal pad and heatsink fins.**

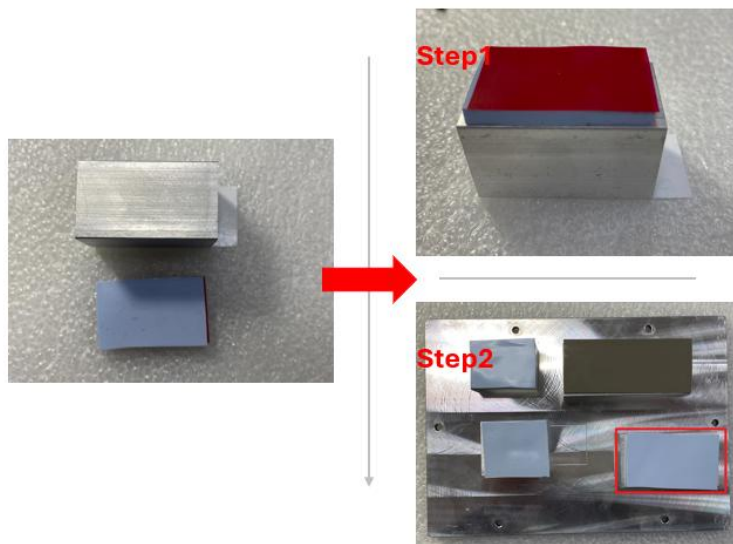

**Step 6** Install SIM card bracket and tighten the screws (by option).

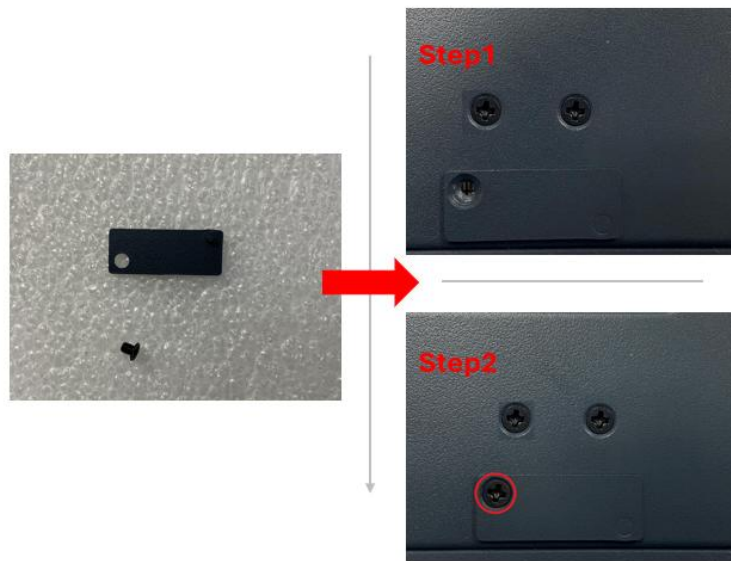

**Step 7** Put the cover back to the system and fasten screws tight close the chassis.

## 2.4 Installing NVMe Module

### AC

Step 1 Turn off the system.

Step 2 Loosen all screws of the cover and remove the cover from the system.

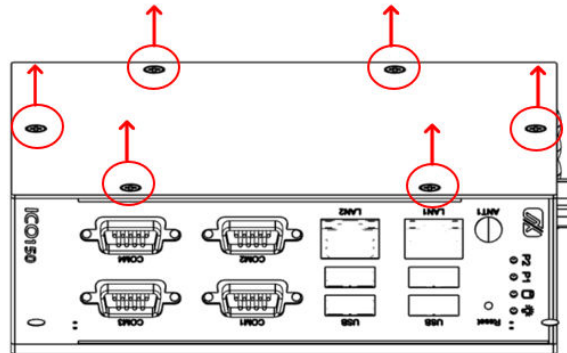

Step 3 Install 2242 NVMe module extension brace.

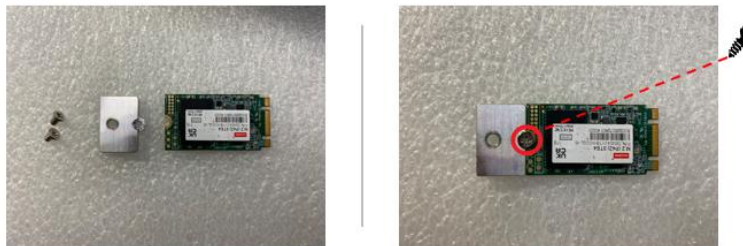

Step 4 Insert the 2242 NVMe module and screws it tight..



**Step 5 Adhesive NVMe module thermal pad and heatsink fins.**

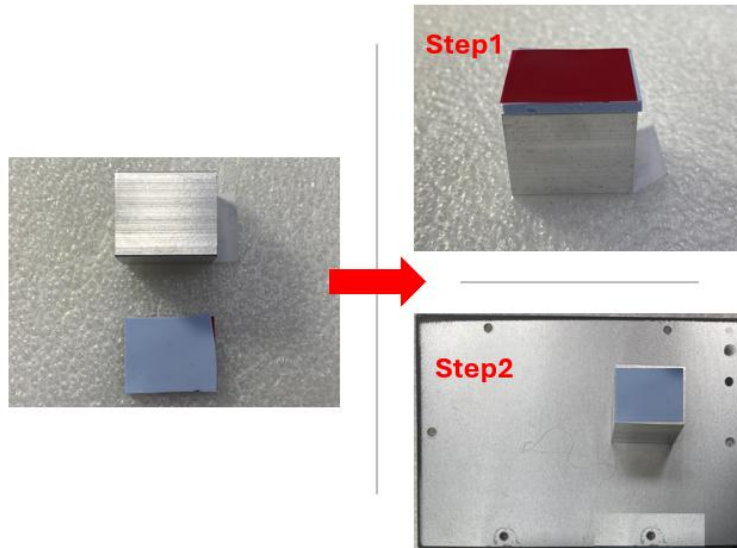

**Step 6 Put the cover back to the system and fasten screws tightly close the chassis.**

**AW**

**Step 1 Turn off the system.**

**Step 2 Loosen all screws of the cover and remove the cover from the system.**

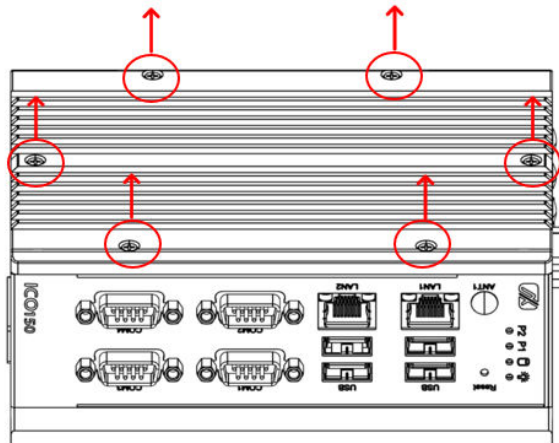

**Step 3 Install 2242 NVMe module extension brace.**

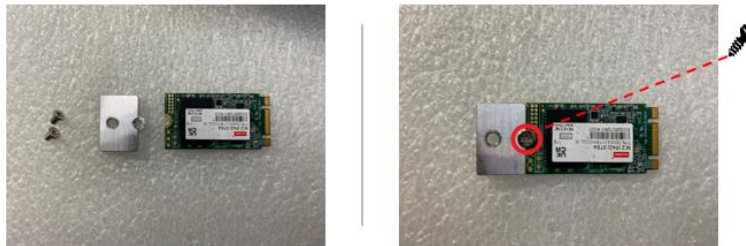

**Step 4 Insert the 2242 NVMe module and screws it tight..**



**Step 5 Adhesive NVMe module thermal pad and heatsink fins.**

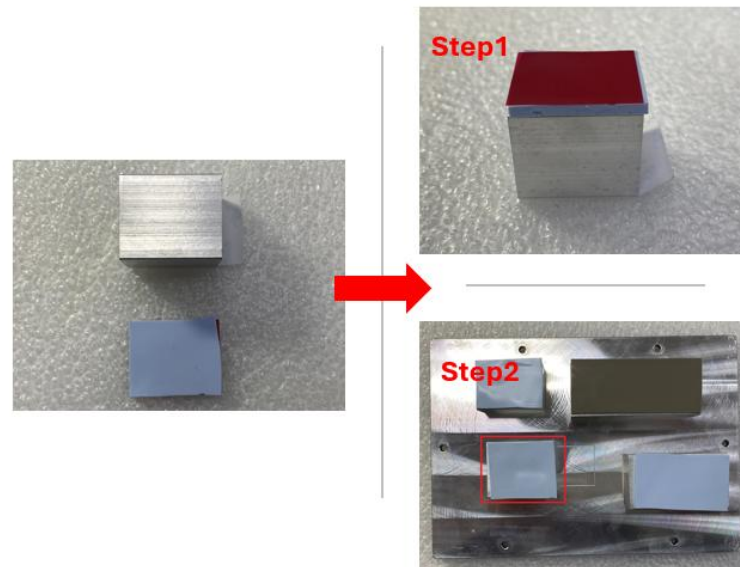

**Step 6 Put the cover back to the system and fasten screws tightly close the chassis.**

## 2.5 Installing Din-rail Mounting (Screw: M3 x 6 4pcs)

Step 1 Prepare Din-rail Mount assembling components (screws and bracket) ready.

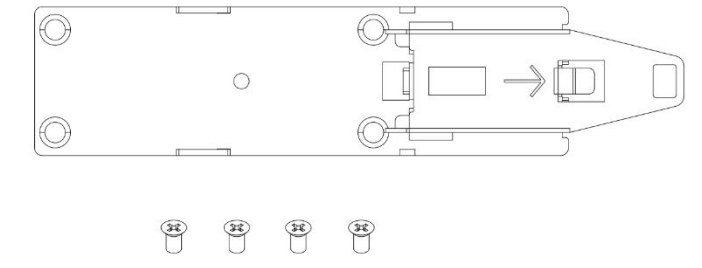

Step 2 Assembly the bracket to the system and fasten screws tight.

Method 1:

AC Mode

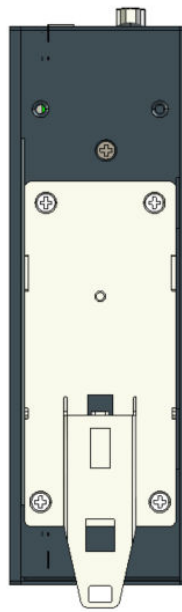

AW Mode

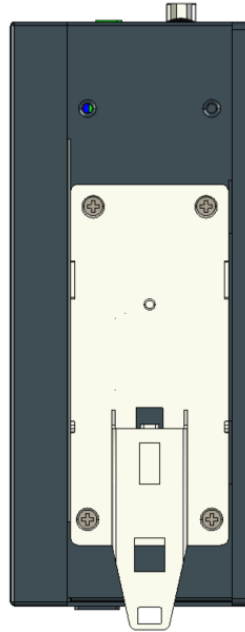

## 2.6 Installing the HDMI Bracket

**Step 1** Prepare the HDMI Bracket Mount assembly components (screws 、 bracket 、 Cable Tie) ready.

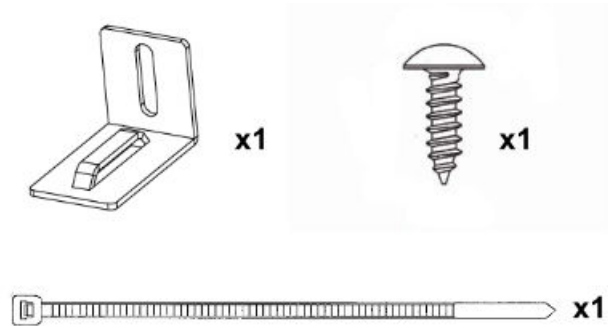

**Step 2** Assemble the bracket to the system and fasten screws tight.

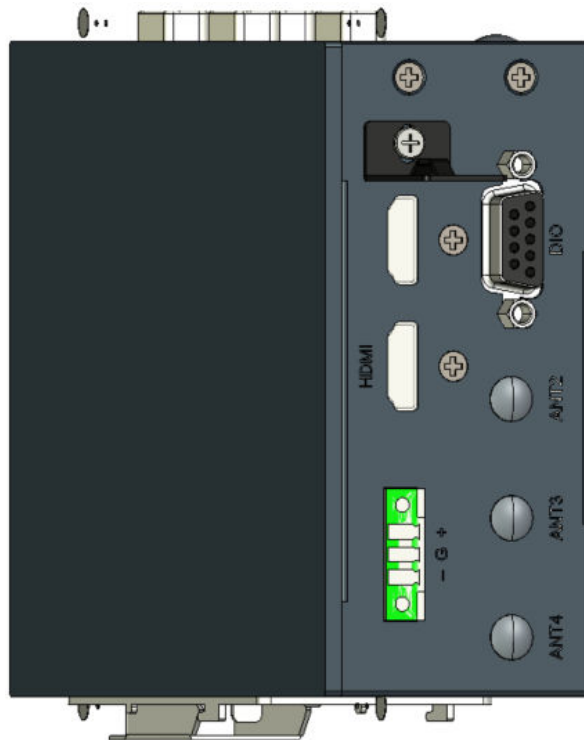

**Step 3** Assemble the cable tie to HDMI Bracket.

## SECTION 3

# AMI UEFI BIOS UTILITY

The AMI UEFI BIOS provides users with a built-in Setup program to modify basic system configuration. All configured parameters are stored in a flash-backed-up to save the Setup information whenever the power is turned off.

### 3.1 Entering Setup

To enter the setup screens, follow the steps below:

1. Turn on the computer and press the <Del> key immediately.
2. After you press the <Del> key, the main BIOS setup menu displays. You can access the other setup screens from the main BIOS setup menu, such as the Advanced and Chipset menus.

### 3.2 The Main Menu

Once you enter the AMI BIOS Aptio Setup Utility, the Main Menu appears on the screen. In the Main Menu, there are several Setup functions and a couple of Exit options for your selection. Use Select Screen Keys (or Move Keys) to select the Setup Page you intend to configure then press <Enter> to accept or enter its sub-menu.

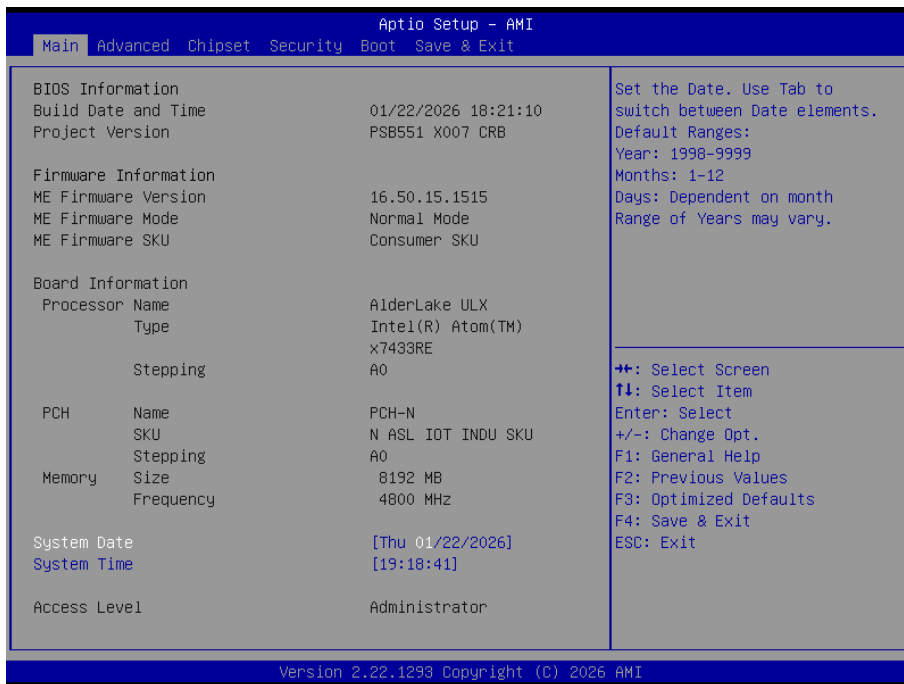

#### System Date

The date format is <day> <month> <date> <year>.

#### System Time

This item shows current time of your system with the format <hour> <minute> <second>. The time is calculated based on the 24-hour military-time clock. For example, 1 p.m. is 13:00:00.

### 3.3 Advanced Features

This Advanced section allows users to configure and improve your system, to set up some system features according to your preference. You can select any of the items in the left frame of the screen to go to the sub menus:

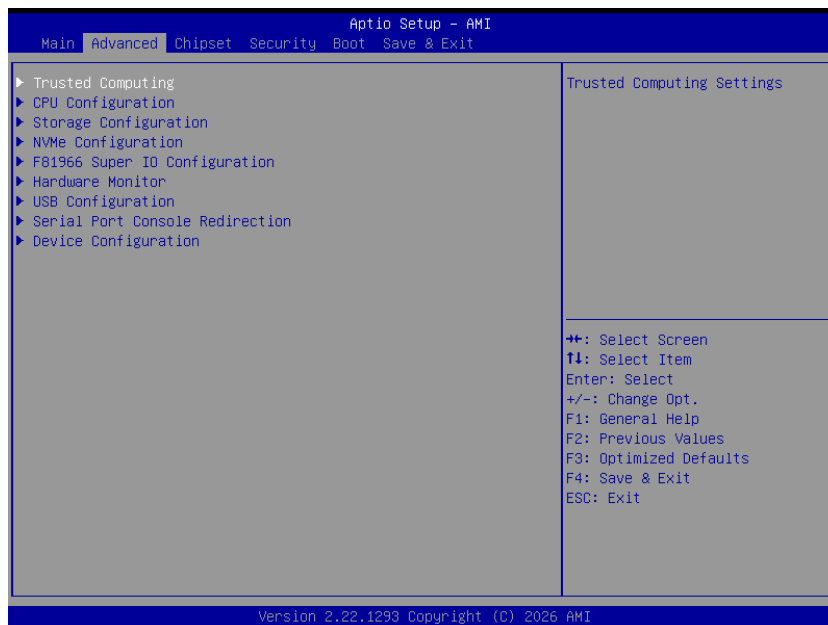

- **Trusted Computing**

Scroll to this item and press <Enter> to view the Trusted Computing information and default set Security Device Support [Enable].

(Please refer below graphics.)



- **CPU Configuration**

Scroll to this item and press <Enter> to view the CPU Configuration informations.

(Please refer below graphics.)



- **Storage Configuration**

Scroll to this item and press <Enter> to view the Storage Configuration information.

(Please refer below graphics.)



### PCIe/Msata Mini Card Configuration

Scroll to this item and press <Enter> to view the SATA Configuration information and choose PCIe Mini Card as PCIe or mSATA.

(Please refer below graphics.)

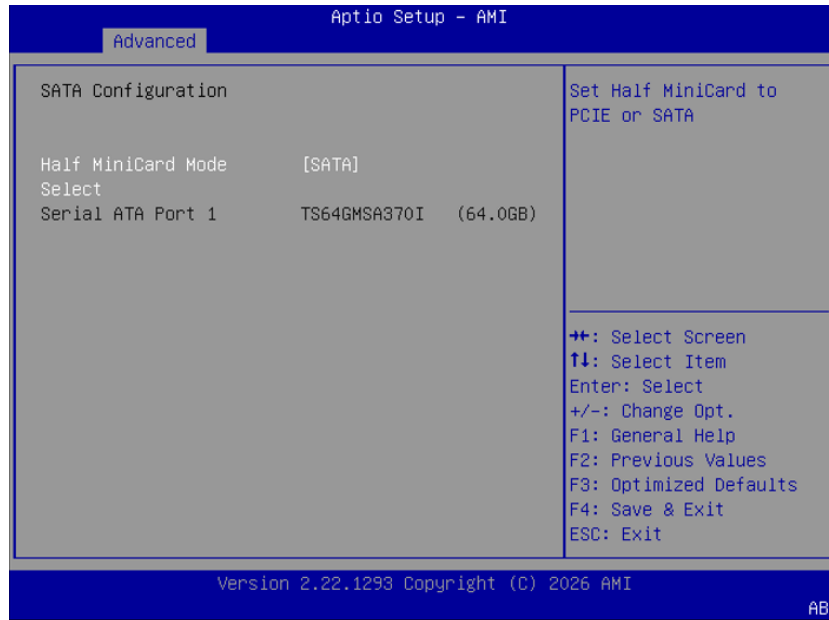

- **NVME Configuration**

Scroll to this item and press <Enter> to view the NVME Configuration information.

(Please refer below graphics.)

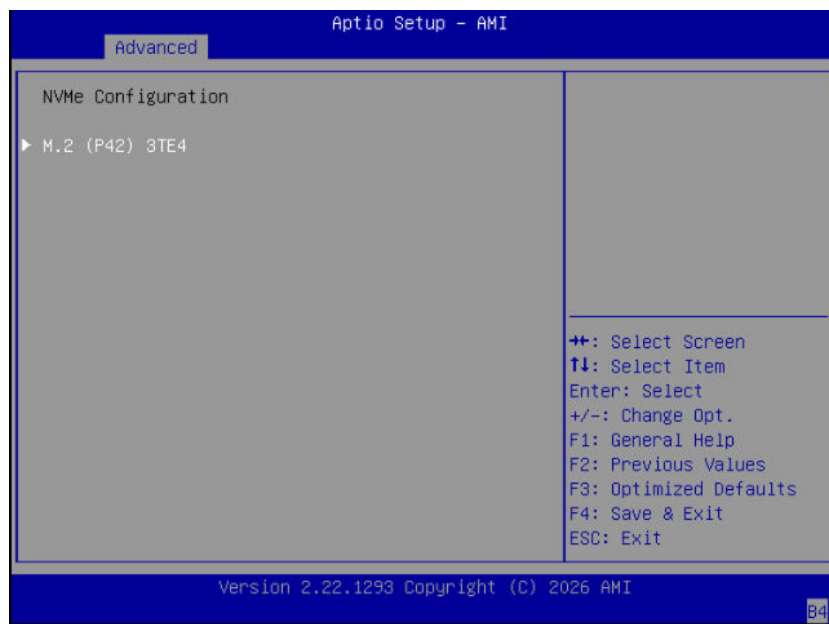

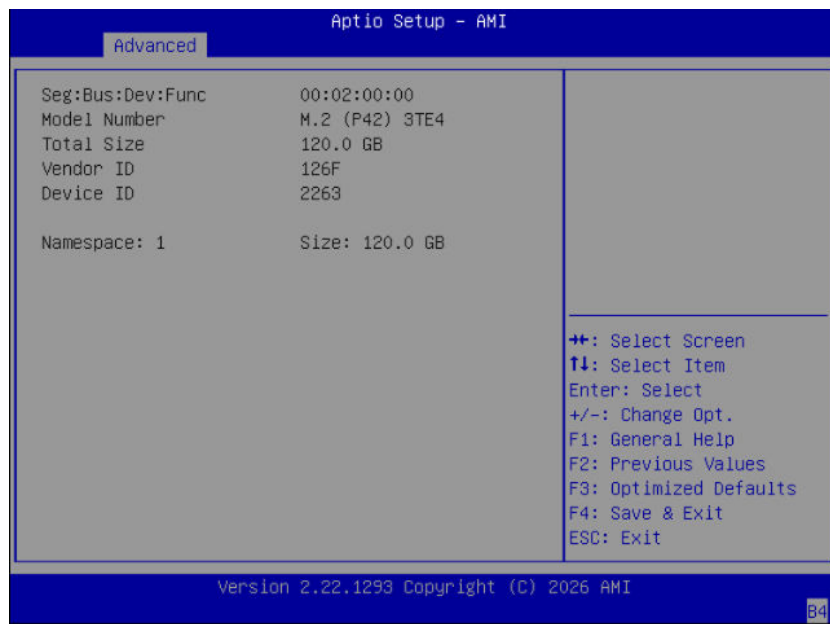

- **F81966 Super IO Configuration**

The default setting for all Serial Ports are RS232.

You can change the setting by selecting the value you want in each COM Port Type.

Supports RS422 & RS485 mode.

(Please refer below graphics.)

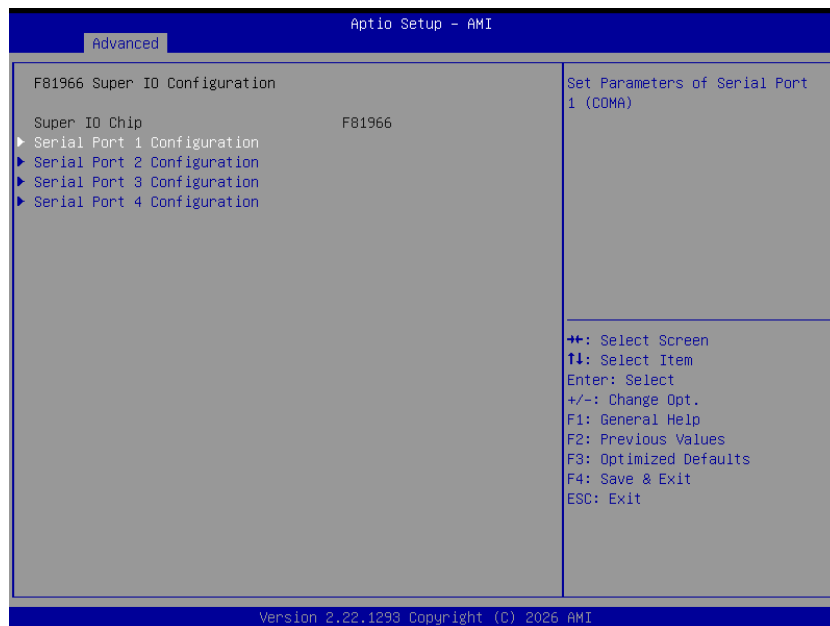

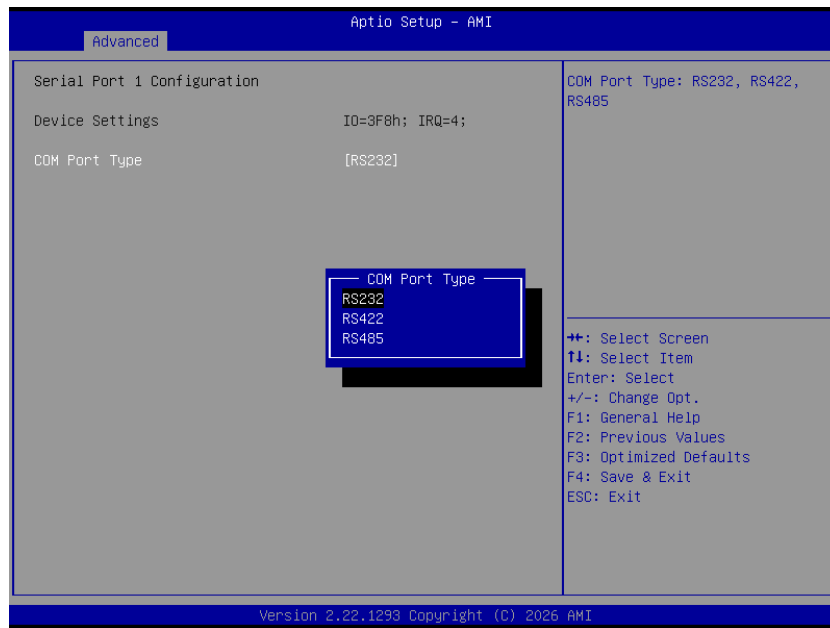

- **Hardware Monitor**

Scroll to this item and press <Enter> to view the monitor hardware status.

(Please refer below graphics.)

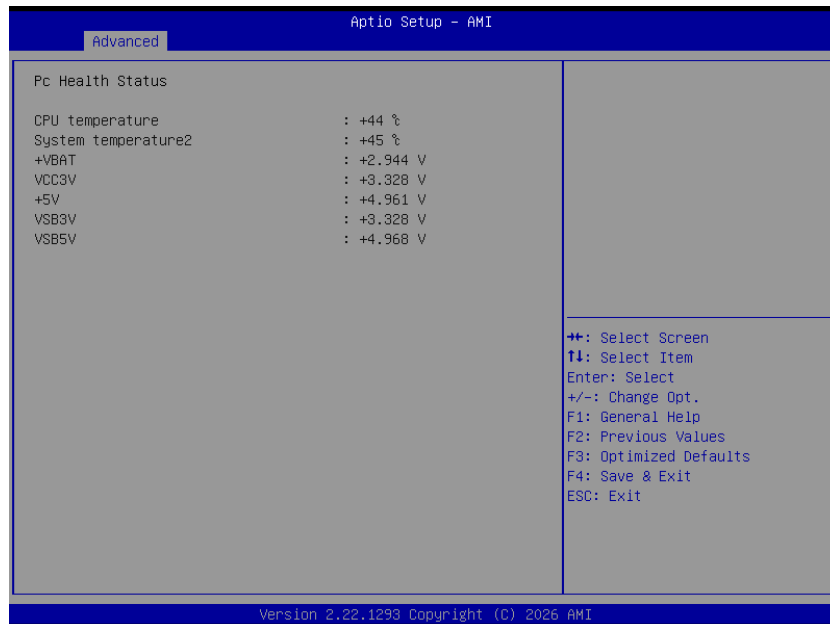

- **USB Configuration**

Scroll to this item and press <Enter> to view the USB Configuration informations.  
 (Please refer below graphics.)

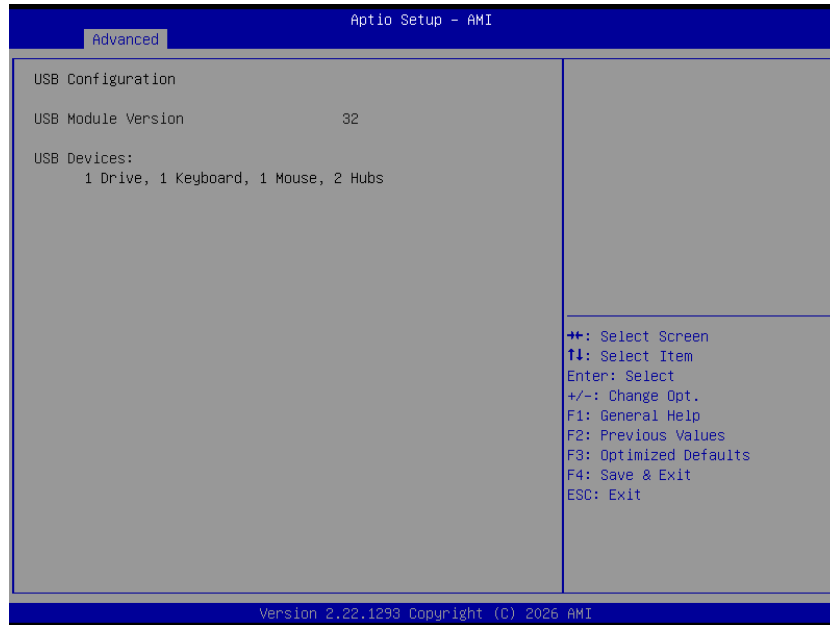

- **Serial Port Console Redirection**

Only COM1 has the console redirection function.

The default setting for the console redirection function is [Disabled]

And you can further change the setting by selecting or setting the value you want in each function as the following pictures.

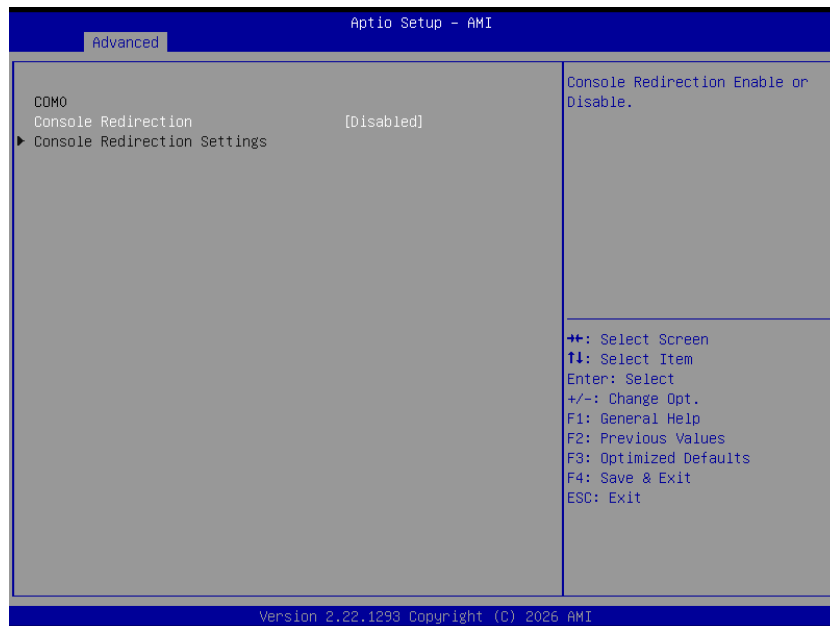

And you can further change the setting by selecting or setting the value you want in each function as the following pictures.

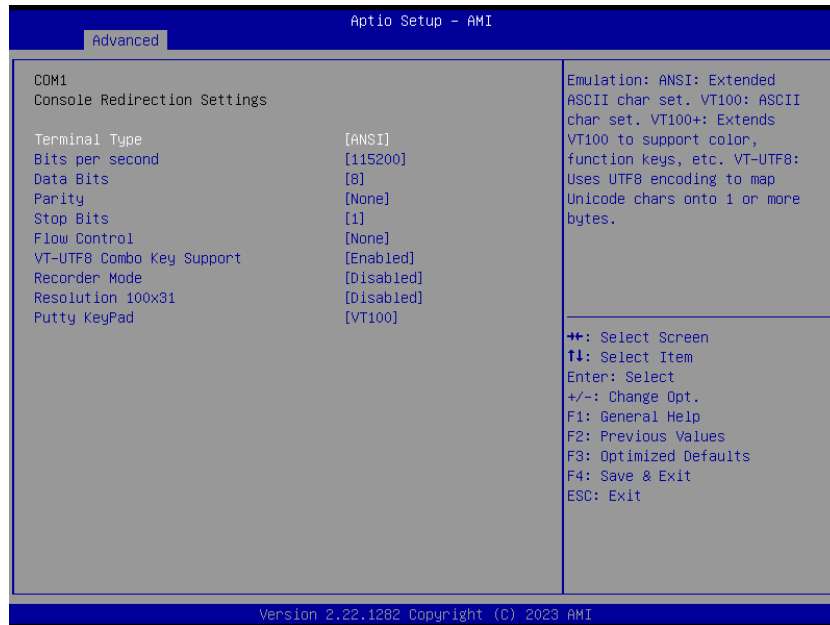

- **Device Configuration**

Scroll to this item and press <Enter> to view the Onboard DIO information.

(Please refer below graphics.)

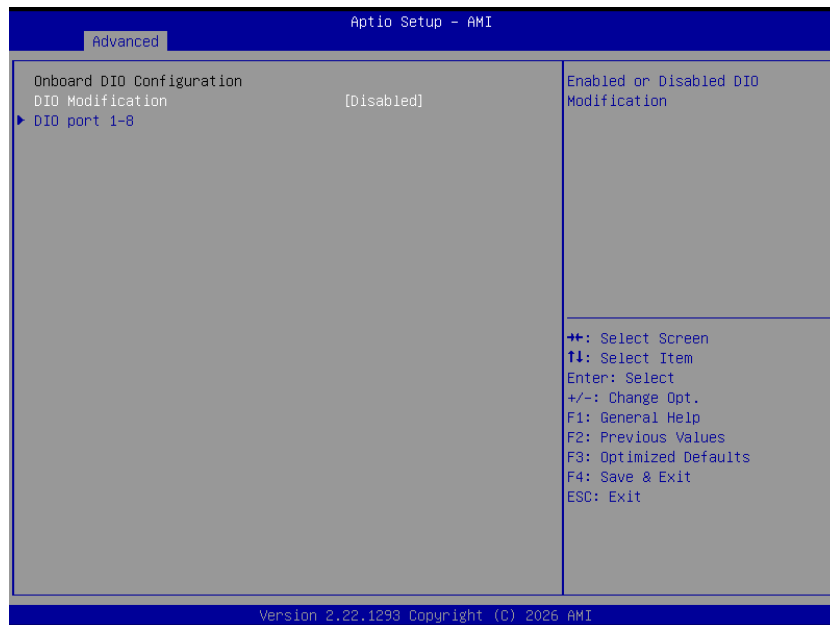

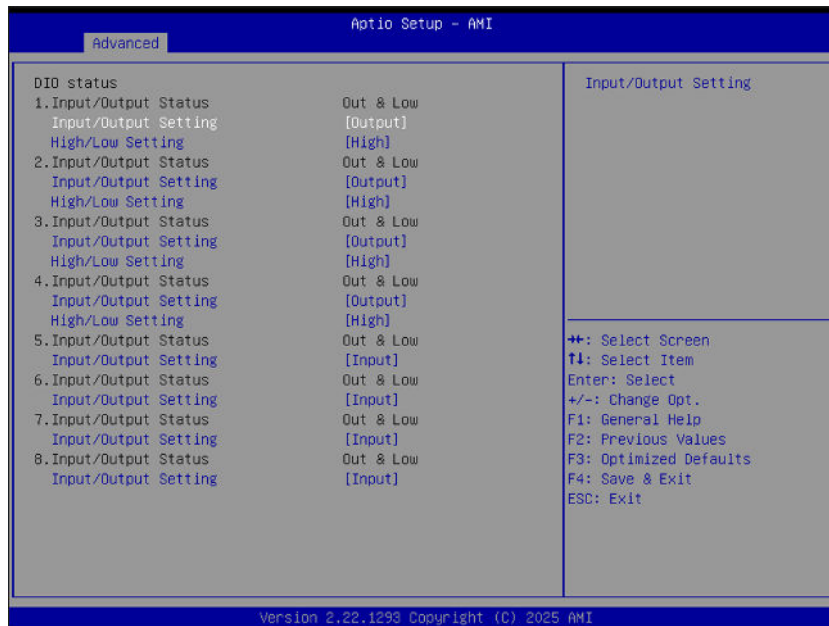
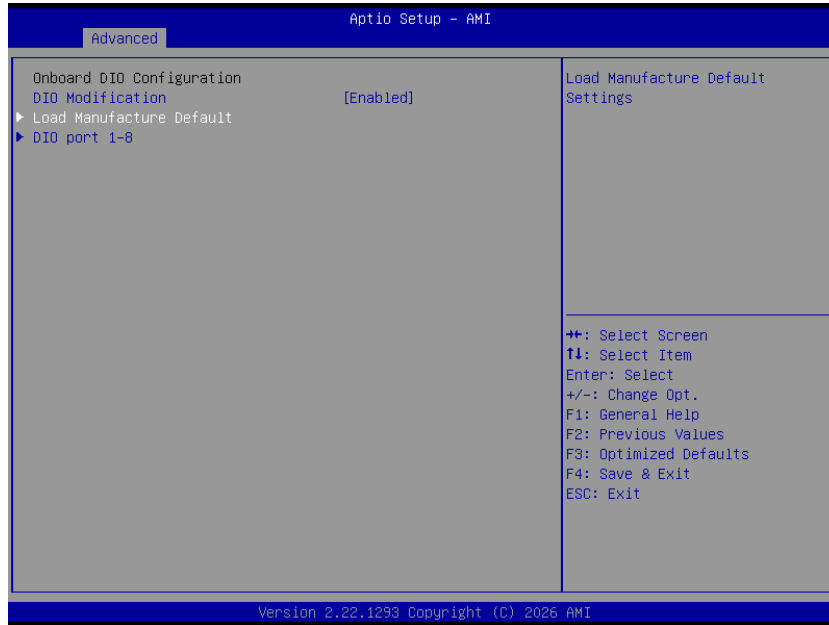

### 3.4 Chipset Feature

- System Agent(SA)Configuration.

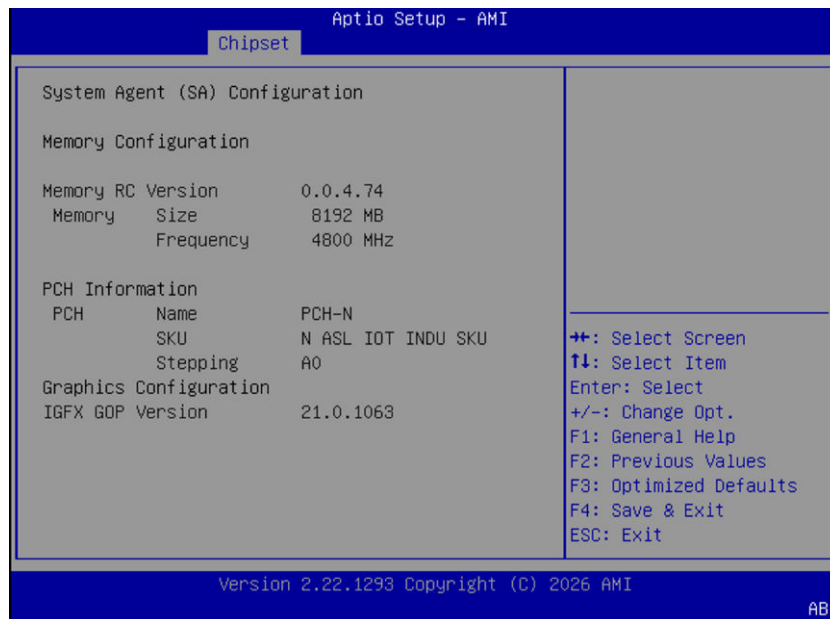
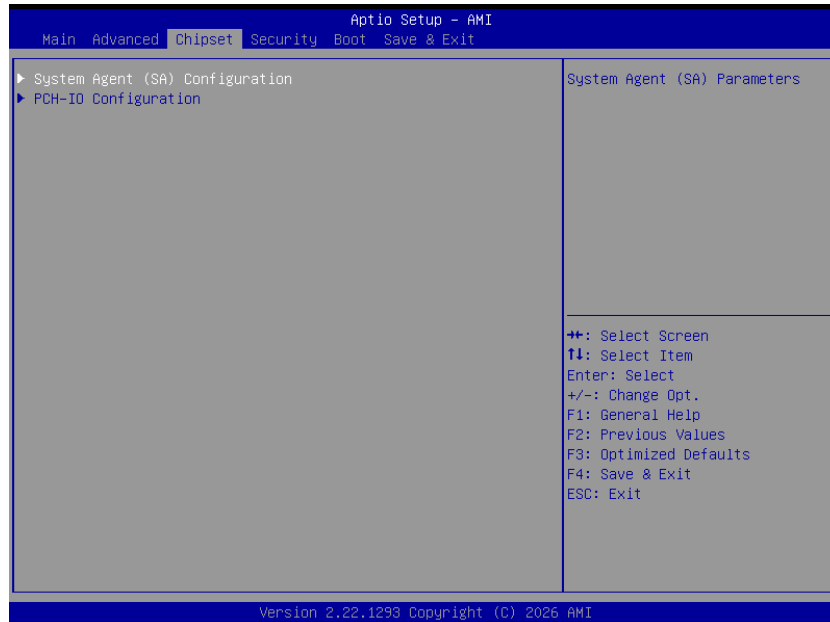

- **PCH-IO Configuration.**

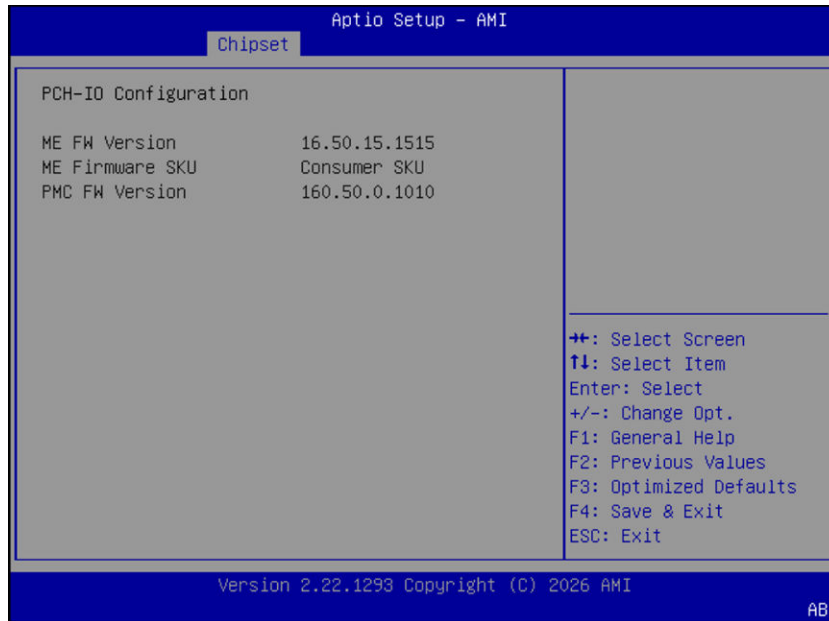

### 3.5 Security

The default setting for Administrator Password is “Not setting passwords”.

The Security menu allows users to change the security settings for the system.

You can set the password for Administrator Password.

(Please refer below graphics.)



**Note:** The BIOS default has no password, when user created the password, please remember the password number, if users forget password the RMA is the only solution.

- Secure Boot

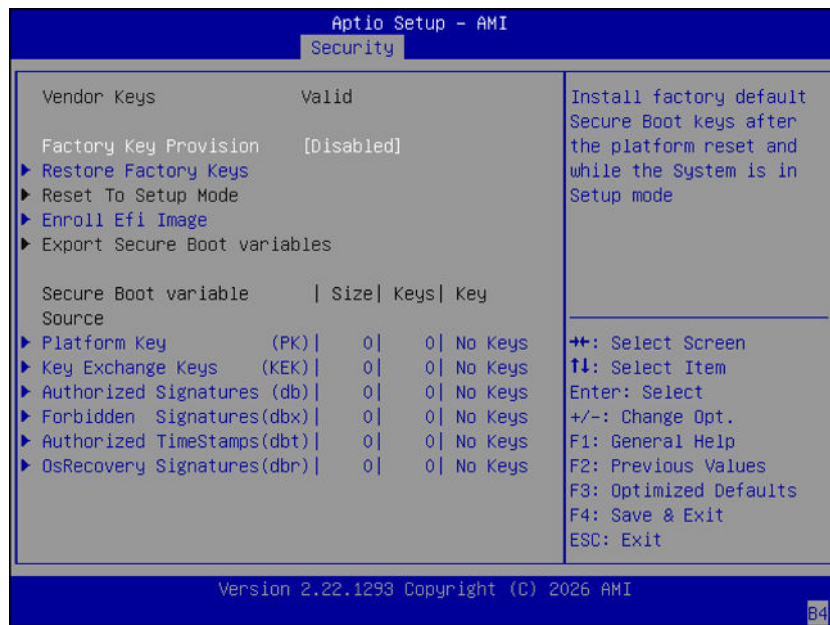
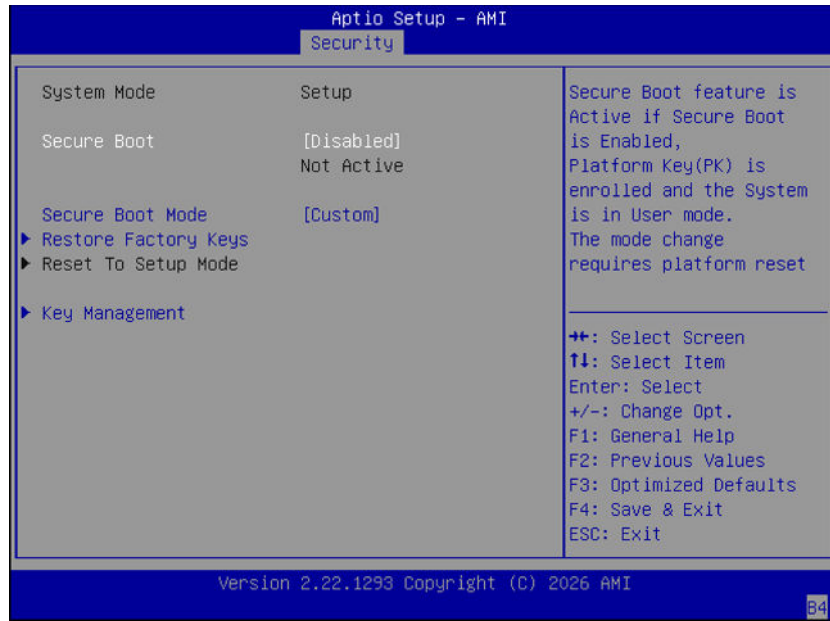

### 3.6 Boot Type

The default setting boot from onboard Launch PXE is [Disabled]

(Please refer below graphics.)



The Boot Option Priorities can select by Boot Option #1, #2..., If user is using a USB Device.

(Please refer below graphics.)

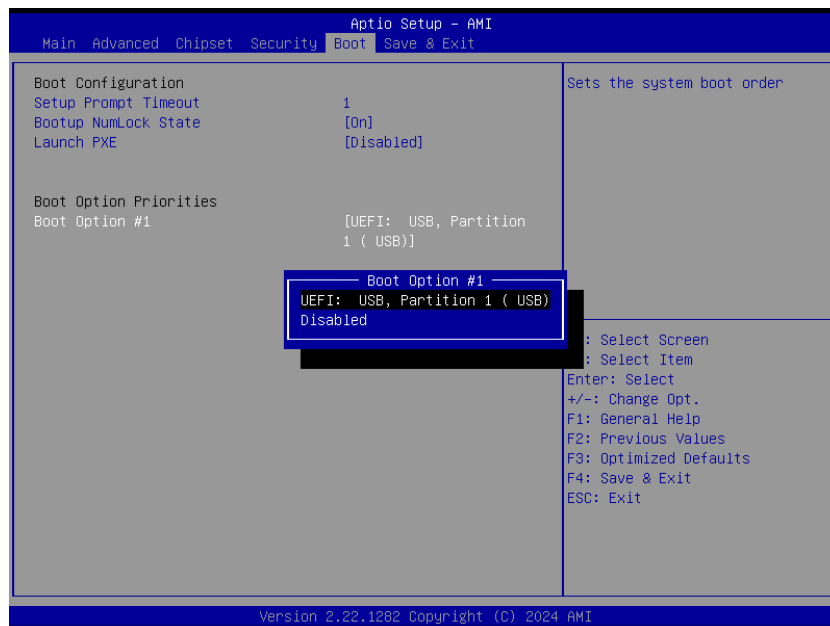

### 3.7 Save & Exit

This section allows you to determine whether or not to accept your modifications.

(Please refer below graphics.)

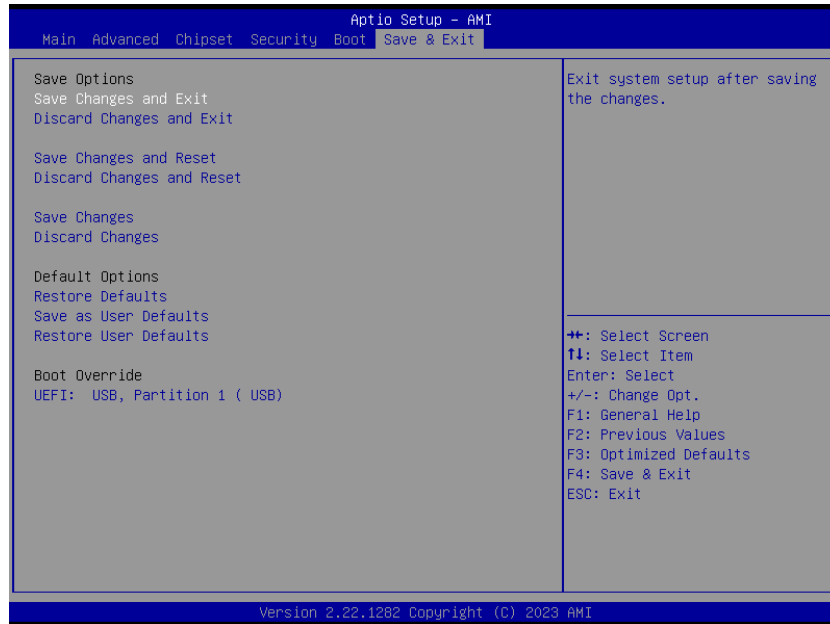

## APPENDIX A WATCHDOG TIMER

### About Watchdog Timer

After the system stops working for a while, it can be auto-reset by the watchdog timer. The integrated watchdog timer can be set up in the system reset mode by program.

### How to Use Watchdog Timer

The following example enables configuration using debug tool.

```
#include <stdio.h>
#include <stdlib.h>

#include <sys/io.h>

#define SIO_INDEX 0x2E
#define SIO_DATA 0x2F

#define SIO_ENTRY_KEY 0x87
#define SIO_EXIT_KEY 0xAA

#define SIO_LD_WDT 0x07

#define SIO_REG_LDN 0x07
#define SIO_REG_ACTIVATE 0x30
#define SIO_REG_IOBASE_HIGH 0x60
#define SIO_REG_IOBASE_LOW 0x61

#define WDT_IOBASE_HIGH 0x0A
#define WDT_IOBASE_LOW 0x10
#define WDT_IOBASE 0x0A10
#define WDT_CONFIG 0x05
#define WDT_TIME 0x06
```

```
int main()
{
    unsigned char Count = 10; // 10 Seconds
    unsigned char DataBuffer; // Operate Io Data

    //Get Io Port Read/Write Permission
    iopl(3);

    //Enter SIO Config
    outb_p ( SIO_ENTRY_KEY, SIO_INDEX);
    outb_p ( SIO_ENTRY_KEY, SIO_INDEX);

    // Set WDT IOBASE
    // Select Logical Device = 07 (WDT)
    outb_p ( SIO_REG_LDN , SIO_INDEX);
    outb_p ( SIO_LD_WDT , SIO_DATA);

    // set IOBase
    outb_p ( SIO_REG_IOBASE_HIGH , SIO_INDEX);
    outb_p ( WDT_IOBASE_HIGH , SIO_DATA);

    outb_p ( SIO_REG_IOBASE_LOW , SIO_INDEX);
    outb_p ( WDT_IOBASE_LOW , SIO_DATA);

    // Activate Wdt IO Decode
    outb_p ( SIO_REG_ACTIVATE , SIO_INDEX);
    outb_p ( 1 , SIO_DATA);

    //Exit SIO Config
    outb_p ( SIO_EXIT_KEY, SIO_INDEX);

    // Clear And Set Wdt Status
    /*
```

**Wdt Config Reg Bit Definition****7 : Reserved****6 : WDT time out Status (Write 1 Clear)****5 : Watch dog counting Enable****4 : Set Output mode (0 Level,1 Edge)****3 : Time Unit (0 : 1sec , 1: 60Sec)****2 : Output Polarity (0 : low active , 1 : High active)****1-0 : (output pulse width of Wdtrst# ,****00 1ms , 01 25ms ,****10 125ms ,11 :5sec)**

\*/

outb\_p ( 0x40 , WDT\_IOBASE + WDT\_CONFIG);

//Set WatchDog Count Time

outb\_p ( Count , WDT\_IOBASE + WDT\_TIME);

//Start WatchDog Count

outb\_p ( 0x20 , WDT\_IOBASE + WDT\_CONFIG);

//Print Remain Time

while(1)

{

DataBuffer = inb\_p ( WDT\_IOBASE + WDT\_TIME );

printf(" reset in %d sec\n",DataBuffer);

}

return 0;

}