

# USER'S MANUAL

## **EIO118**

**Full-size LTE Cat.4 mini card with  
GNSS module.**

**User's Manual**



[www.axiomtek.com](http://www.axiomtek.com)

## **Disclaimers**

This manual has been carefully checked and believed to contain accurate information. Axiomtek Co., Ltd. assumes no responsibility for any infringements of patents or any third party's rights, and any liability arising from such use.

Axiomtek does not warrant or assume any legal liability or responsibility for the accuracy, completeness or usefulness of any information in this document. Axiomtek does not make any commitment to update the information in this manual.

Axiomtek reserves the right to change or revise this document and/or product at any time without notice.

No part of this document may be reproduced, stored in a retrieval system, or transmitted, in any form or by any means, electronic, mechanical, photocopying, recording, or otherwise, without the prior written permission of Axiomtek Co., Ltd.

## **CAUTION**

If you replace wrong batteries, it causes the danger of explosion. It is recommended by the manufacturer that you follow the manufacturer's instructions to only replace the same or equivalent type of battery, and dispose of used ones.

**©Copyright 2024 Axiomtek Co., Ltd.**







**All Rights Reserved**

**November 2024, Version A1**

**Printed in Taiwan**

## Safety Instruction

By following the safety guidelines below, you can ensure your personal safety and help protect the product and work environment from potential damage.

	Road safety first! When you drive, do not use the hand held devices even if it has a hand-free feature. Please stop and call!
	Please turn off the mobile device before boarding. The wireless feature of the mobile device is not allowed on the aircraft to prevent interference with the aircraft communication system. Ignoring this note may result in flight safety issue or even breaking the law.
	When in a hospital or health care facility, please be aware of restrictions on the use of mobile devices. Radio frequency interference may cause medical equipment to malfunction, so it may be necessary to turn off the mobile device.
	The mobile device does not guarantee that an effective connection can be made under any circumstances, for example, when there is no prepayment for the mobile device or the (U)SIM is invalid. When you encounter the above situation in an emergency, remember to use an emergency call, while keeping your device turned on and in areas where signal is strong.
	Your mobile device receives and transmits RF signals when it is powered on. Radio interference occurs when it is near televisions, radios, computers, or other electronic devices.
	Keep the mobile device away from flammable gases. Turn off the mobile device when near gas stations, oil depots, chemical plants or explosive workplaces. There is a safety hazard in operating electronic equipment in any potentially explosive environment.

## Reference Standards

This design of the product complies with the following standards:

3GPP TS 51.010-1 V10.5.0:

Mobile Station (MS) conformance specification; Part 1: Conformance specification

3GPP TS 34.121-1 V10.8.0:

User Equipment (UE) conformance specification; Radio transmission and reception (FDD); Part 1: Conformance specification

3GPP TS 34.122 V10.1.0:

Technical Specification Group Radio Access Network; Radio transmission and reception (TDD)

3GPP TS 36.521-1 V10.6.0:

User Equipment (UE) conformance specification; Radio transmission and reception; Part 1: Conformance testing

3GPP TS 21.111 V10.0.0:

USIM and IC card requirements

3GPP TS 51.011 V4.15.0:

Specification of the Subscriber Identity Module -Mobile Equipment (SIM-ME) interface

3GPP TS 31.102 V10.11.0:

Characteristics of the Universal Subscriber Identity Module (USIM) application

3GPP TS 31.11 V10.16.0:

Universal Subscriber Identity Module (USIM) Application Toolkit(USAT)

3GPP TS 36.124 V10.3.0:

Electro Magnetic Compatibility (EMC) requirements for mobile terminals and ancillary equipment

3GPP TS 27.007 V10.0.8:

AT command set for User Equipment (UE)

3GPP TS 27.005 V10.0.1:

Use of Data Terminal Equipment - Data Circuit terminating Equipment (DTE - DCE) interface for Short Message Service (SMS) and Cell Broadcast Service (CBS)

# Table of Contents

---

Disclaimers.....	ii
Safety Instruction.....	iii
Reference Standards .....	iv
<b>Section 1 Introduction.....</b>	<b>1</b>
1.1 Features .....	1
1.2 Specifications.....	2
<b>Section 2 Module and Pin Assignments.....</b>	<b>5</b>
2.1 PCI express Mini Card Interface .....	5
2.1.1 Pin Assignment.....	5
2.1.2 Pin Description .....	6
2.2 Power Supply Table .....	8
2.3 Reset Mode Control Signal.....	9
2.4 USB Interface.....	9
2.5 (U)SIM Interface .....	10
2.5.1 (U)SIM Pin Definition.....	10
2.5.2 (U)SIM Design Requirements on the Mainboard .....	10
2.6 Status Indicator .....	11
<b>Section 3 Antenna Interface .....</b>	<b>13</b>
3.1 Operating Frequency Band .....	14
3.1.1 EIO118-EAU-LTE Operating Band, Transmission Power and Sensitivity .	14
3.1.2 EIO118-JP-LTE Operating Band, Transmission Power and Sensitivity ....	16
3.1.3 EIO118-AMATT-LTE & EIO118-AMVzW-LTE Operating Band, Transmission Power and Sensitivity .....	18
3.2 GNSS Receiver .....	20
3.3 Antenna Design Requirements .....	21
3.4 Antenna RF Connector .....	23
<b>Section 4 Structure Dimensions Specification.....</b>	<b>25</b>
<b>Section 5 EIO118 MCU Commands List .....</b>	<b>27</b>
5.1 EIO118 MCU Control Interface .....	27
5.2 EIO118 MCU Commands List .....	28

**This page is intentionally left blank.**

# Section 1

## Introduction

			
E39P118100 EIO118-EAU-LTE	E39P118102 EIO118-JP-LTE	E39P118101 EIO118-AMATT-LTE	E39P118103 EIO118-AMVzW-LTE

### 1.1 Features

The EIO118 series is an LTE wireless communication module in a PCIe Mini Card form factor, supporting multiple network formats and bands, including LTE-TDD, LTE-FDD, TD-SCDMA, WCDMA, EVDO, CDMA, and GSM. It delivers LTE Cat 4 speeds, offering up to 150Mbps for downlink and 50Mbps for uplink, making it an ideal solution for industrial routing, security, and Internet of Vehicles (IoV) applications.

- Supports LTE Cat 4 with up to 50Mbps uplink speed
- Supports LTE Cat 4 with up to 150Mbps downlink speed.
- Wide operating temperature range from -40°C to +70°C
- Seamless switching between modules and SIM card slots for flexible connectivity
- Integrated watchdog for enhanced system reliability and availability
- Communication Manager enables remote monitoring and real-time management
- Regional support through corresponding models

## 1.2 Specifications

Model Name	EIO118-EAU-LTE	EIO118-JP-LTE	EIO118-AMATT -LTE	EIO118-AMVzW -LTE
P/N	E39P118100	E39P118102	E39P118101	E39P118103
Supported Frequency	LTE FDD: Band 1/3/5/7/8/20/28 LTE TDD: Band 38/40/41 WCDMA: Band 1/5/8 GSM/GPRS/EDGE: 850/900/1800MHz	LTE FDD: Band 1/3/8/11/18/19/21/26/28 LTE TDD: Band 41 WCDMA: Band 1/6/8/19	LTE FDD: Band 2/4/5/12/13/17/66/71 WCDMA: Band 2/4/5	
Operating Frequency	LTE FDD: Please refer to the specifications listed above.			
	LTE TDD: Please refer to the specifications listed above.			
	WCDMA/HSPA+: Please refer to the specifications listed above.			
	GSM/GPRS/EDGE: Please refer to the specifications listed above.			
TX Power	GSM850: 32.5dBm±1dBm GSM900: 32.5dBm±1dBm DCS1800:29.5dBm±1dBm WCDMA : 23.5dBm±1dBm LTE FDD: 23.0dBm±1dBm LTE TDD: 23.0dBm±1dBm	WCDMA/HSPA+ : 3.5dBm±1.5dBm LTE FDD: 23.0dBm±2dBm LTE TDD: 23.0dBm±2dBm	WCDMA : 23.5dBm±1dBm LTE FDD: 23.0dBm±1dBm	
Downlink Speed	LTE FDD: 150Mbps LTE TDD: 130Mbps WCDMA: 384 kbps DC-HSPA+: 42Mbps EDGE: 296Kbps GPRS: 107Kbps	LTE FDD: 150Mbps LTE TDD: 130Mbps DC-HSPA+: 42Mbps WCDMA: 384Kbps	LTE FDD: 150Mbps WCDMA: 384Kbps DC-HSPA+: 42Mbps	
Uplink Speed	LTE FDD: 50Mbps LTE TDD: 30.5Mbps WCDMA: 384 kbps DC-HSPA+:	LTE FDD: 50Mbps LTE TDD: 30.5Mbps DC-HSPA+:	LTE FDD: 50Mbps WCDMA: 384Kbps DC-HSPA+: 5.76Mbps	

	5.76Mbps EDGE: 236.8Kbps GPRS: 85.6Kbps	5.76Mbps WCDMA: 384Kbps	
Power			
Power Supply	3.0V ~ 3.6V (Typ = 3.3V)		
Power consumption	Stand by Less than 1W (VCC=3.3V , 25°C)		
Temperature	Normal Operation: -40°C to +70°C Storage Temperature: -40°C to +85°C		
Physical and Form Factor Characteristics			
Physical characteristics	Package: PCI express Mini Card interface 52PIN		
	Size:(50.8±0.15) mm× (29.85±0.15) mm× (5.3±0.3) mm		
	Weight: <10.5g		
Interface			
Interface	SIM Card: 1.8V/3.0V		
	USB 2.0		
Antenna	Main/DIV/GNSS		
DFOTA/FOAT	Yes		
System Indicator	The module's operation status is displayed		
	The mobile's communication status is displayed		
Software			
OS	Supports Linux and Windows		
AT Command Set	3GPP TS 27.007 and 27.005, and proprietary Fibocom AT commands		
Axiomtek Control command set	Supports built-in AXIOMTEK commands for monitoring and control, featuring the following functions: Hardware reset. Software reset. SIM Slot switching between the module and the mainboard. Operation information logging and monitoring.		
Certifications			
Certifications	Regulation: CE-RED/RCM/NCC/ ANATEL/RoHS Operator: DTAG	Regulation: RoHS/ JATE/TELEC/R EACH Operator: DOCOMO/ KDDI/SoftBank	Regulation: FCC/IC/RoHS Operator: Verizon/AT&T/T-Mobile

**This page is intentionally left blank.**

# Section 2

## Module and Pin Assignments

### Application Interface

#### 2.1 PCI express Mini Card Interface

The EIO118 series MiniPCIe module adopts a PCI express Mini Card interface, with a total of 52 pins.

##### 2.1.1 Pin Assignment

Signal Name	Pin		Signal Name	Pin
WAKE#	1		Module VCC	2
NC	3		GND	4
NC	5		NC	6
NC	7		UIM_PWR	8
GND	9		UIM_DATA	10
NC	11		UIM_CLK	12
NC	13		UIM_RESET	14
GND	15		UIM_VPP	16
NC	17		GND	18
NC	19		NC	20
GND	21		PERST#	22
NC	23		Module VCC	24
NC	25		GND	26
GND	27		NC	28
GND	29		NC	30
NC	31	NC	32	
NC	33	GND	34	
GND	35	USB_DN	36	
GND	37	USB_DP	38	
Module VCC	39	GND	40	
Module VCC	41	NC	42	

GND	43		NC	44
NC	45		NC	46
NC	47		NC	48
NC	49		GND	50
NC	51		Module VCC	52

### 2.1.2 Pin Description

Pin	Pin Name	I/O	Level	Description
1	WAKE#	IO		Reserved
2	Module VCC	PI	3.3V DC in	Module power supply
3	NC			Reserved
4	GND	G		Ground
5	NC			Reserved
6	NC			Reserved
7	NC			Reserved
8	UIM_PWR	PO	For 1.8V (U)SIM: Vmax=1.9V Vmin=1.7V For 3.0V (U)SIM Vmax=3.05V Vmin=2.7V Iomax=50mA	(U)SIM power
9	GND	G		Ground
10	UIM_DATA	IO	For 1.8V (U)SIM: VILmax=0.6V VIHmin=1.2V VOLmax=0.45V VOHmin=1.35V For 3.0V (U)SIM: VILmax=1.0V                      VIHmin=1.95V VOLmax=0.45V VOHmin=2.55V	(U)SIM data signal
11	NC			Reserved
12	UIM_CLK	O	For 1.8V (U)SIM: VOLmax=0.45V VOHmin=1.35V For 3.0V (U)SIM:	(U)SIM clock signal

			VOLmax=0.45V VOHmin=2.55V	
13	NC			Reserved
14	UIM_RESET	O	For 1.8V (U)SIM: VOLmax=0.45V VOHmin=1.35V For 3.0V (U)SIM: VOLmax=0.45V VOHmin=2.55V	(U)SIM reset signal
15	GND	G		Ground
16	NC			Reserved
17	NC			Reserved
18	GND	G		Ground
19	NC			Reserved
20	NC			Reserved
21	GND	G	-	Ground
22	PERST#	I	VIHmax=3.6V VIHmin=1.5V VILmax=0.3V	Module reset signal
23	NC			Reserved
24	Module VCC	PI	3.3V DC in	Module power supply
25	NC			Reserved
26	GND	G		Ground
27	GND	G		Ground
28	NC			Reserved
29	GND	G		Ground
30	NC			Reserved
31	NC			Reserved
32	NC			Reserved
33	NC			Reserved
34	GND	G		Ground
35	GND	G		Ground
36	USB_DM	IO	USB2.0 standard specification	USB signal DM
37	GND	G		Ground
38	USB_DP	IO	USB2.0 standard specification	USB signal DP
39	Module VCC	PI	3.3V DC in	Module power supply
40	GND	G		Ground

41	Module VCC	PI	3.3V DC in	Module power supply
42	NC			Reserved
43	GND	G		Ground
44	NC			Reserved
45	NC			Reserved
46	NC			Reserved
47	NC			Reserved
48	NC			Reserved
49	NC			Reserved
50	GND	G		Ground
51	NC			Reserved
52	Module VCC	PI	3.3V DC in	Module power supply



**Note:** Keep the unused pins floating.

## 2.2 Power Supply Table

The power interfaces of NL668 series MiniPCIe module are shown in the following table:

Pin Name	I/O	Pin	Description
Module VCC	PI	2、24、39、41、52	The module's power supply is 3.0V to 3.6V, with a nominal value of 3.3V.
GND	G	4、9、15、18、21、26、27、29、34、35、37、40、43、50	Ground

## 2.3 Reset Mode Control Signal

The EIO118 series MiniPCle module provides one control signal for the reset operation. The pin definition is shown as follows:

Pin Name	I/O	Pin Num	Description
PERST#	I	22	Connect this pin to the system platform reset. If the function is not used, please pull this pin high to 3.3V. pin.

The EIO118 series MiniPCle module can be reset by hardware and AT command.

Reset Mode	Reset Method
Module reset	Use the module's built-in command, CMD_HRST, to reset the module. Refer chapter 5.2
	Use AT Command to reset Module, AT+CFUN=15
MCU reset	Use Module build-in command to reset MCU, CMD_MCU_RST. Refer chapter 5.2

## 2.4 USB Interface

EIO118 series MiniPCle module supports USB 2.0 and is compatible with USB High-Speed (480Mbps/s). Refer to the "Universal Serial Bus Specification 2.0" for the time slot and electrical characteristics of the EIO118 series MiniPCle module's USB bus.

Pin Name	I/O	Pin No.	Description
USB_DM	IO	36	USB differential data (-)
USB_DP	IO	38	USB differential data (+)



### Note:

- Since the module supports USB 2.0 High-Speed, the equivalent capacitance of the TVS tube on the USB\_DM/DP differential signal cables is required to be less than 1pF, and a 0.5pF capacitance TVS is recommended.
- Connect a 0-ohm resistor to the USB\_DM / DP differential cables;
- USB\_DN and USB\_DP are high-speed differential signal cables, that can achieve a maximum transmission rate of 480 Mbps/s, and must follow the rules below in PCB Layout:  
The controlled differential impedance of the USB\_DN and USB\_DP signal cable's is 90 ohms;  
The USB\_DN and USB\_DP signal cables shall be parallel, equal in length, and should avoid right-angle routing.  
The USB\_DN and USB\_DP signal cables should be routed on the signal layer closest to the ground layer, and the cables must be grounded.

## 2.5 (U)SIM Interface

EIO118 series MiniPCle module support 2 types SIM card interface with switching function, and support 1.8V and 3.0V (U)SIM card.

- Built-in Nano SIM Slot on the Module.
- Support (U)SIM card interface on the Main Board.



**Note:** Only one type can be selected to use, can't operation at the same time!!

### 2.5.1 (U)SIM Pin Definition

Pin Name	I/O	Pin No.	Description
UIM_PWR	PO	8	(U)SIM Power
UIM_DATA	IO	10	(U)SIM Data
UIM_CLK	O	12	Clock Signal
UIM_RESET	O	14	Reset Signal
UIM_VPP	I	44	To detect the (U)SIM card, the pin must be left floating.



### 2.5.2 (U)SIM Design Requirements on the Mainboard

The default (U)SIM card slot setting is on the mainboard. Based on the circuit design, it must meet EMC standards and ESD requirements, while also improving anti-interference capability to ensure that the (U)SIM card works stably. The design needs to strictly adhere to the following rules:

- The (U)SIM card connector should be placed as close to the module as possible, and away from the RF antenna, DCC power supply, clock signal lines, and other strong interface sources.
- Adopt the (U)SIM card connector with metal shield to improve anti-interference capability.
- The length of the cable from the module to the (U)SIM card connector shall not exceed 100mm, as longer cables reduce signal quality.
- USIM\_CLK and USIM\_DATA signals are ground isolated to avoid mutual interference. If it is difficult, the (U)SIM signals need to be ground-protected as a set.
- The filter capacitor and ESD device of the (U)SIM card signal cable should be placed close to the (U)SIM card connector.
- Please select an equivalent capacitor of 22pF to 33pF for ESD device.
- USIM\_DATA should be pulled up to USIM\_VDD with a 10K resistor.

## 2.6 Status Indicator

The EIO118 series MiniPCIe module provides one signal to display the operating status of the module. The status indication pin is shown in the following table:

ITEM	Indicator Color	Function Description	Light /flash status
	Green	Mobile Network Data link is in an established state.	Speed flash
	Green	The module's operating status is good.	Light
	Red	The module's operating status is failed.	Light
	Yellow	The module's operating status is warning.	Light

**This page is intentionally left blank.**

## Section 3

# Antenna Interface

The EIO118 series MiniPCIe module has three antenna interfaces: the main antenna interface, the diversity antenna interface, and GNSS antenna interface. The pin definitions are as follows.

RF Connector Name	Description
CN1	4G/LTE Diversity antenna
CN2	Passive GNSS antenna
CN3	4G/LTE Main antenna

 <p>Fibocom NL668-EAU ANATEL 00730-21-09038 CCAF22Y00560T0</p>	 <p>Fibocom NL668-JP</p>	 <p>Fibocom NL668-AM</p>	 <p>Fibocom NL668-AM</p>
E39P118100 EIO118-EAU-LTE	E39P118102 EIO118-JP-LTE	E39P118101 EIO118-AMATT-LTE	E39P118103 EIO118-AMVzW-LTE

## 3.1 Operating Frequency Band

### 3.1.1 EIO118-EAU-LTE Operating Band, Transmission Power and Sensitivity

EIO118-EAU-LTE Operating Band				
Operating Band	Description	Mode	Tx (MHz)	Rx (MHz)
Band 1	IMT 2100MHz	LTE FDD/WCDMA	1920 - 1980	2110 - 2170
Band 3	DCS 1800MHz	LTE FDD/GSM	1710 - 1785	1805 - 1880
Band 5	CLR 850MHz	LTE FDD/WCDMA/GSM	824 - 849	869 - 894
Band 7	IMT-E 2600MHz	LTE FDD	2500 - 2570	2620 - 2690
Band 8	E-GSM 900MHz	LTE FDD/WCDMA/GSM	880 - 915	925 - 960
Band 20	EUDD 800MHz	LTE FDD	832 - 862	791 - 821
Band 28	700MHz	LTE FDD	703 - 748	758 - 803
Band 38	IMT-E 2600MHz	LTE TDD	2570 - 2620	
Band 40	IMT 2300MHz	LTE TDD	2300 - 2400	
Band 41	BRS/EBS 2500MHZ	LTE TDD	2535-2655	

EIO118-EAU-LTE Transmission Power			
Mode	Band	Tx Power (dBm)	Note
GSM	GSM 850	32.5±1.5	-
	GSM 900	32.5±1.5	-
	DCS 1800	29.5±1.5	-
WCDMA	Band 1	23.5±2	-
	Band 5	23.5±2	-
	Band 8	23.5±2	-
LTE FDD	Band 1	23±2	10MHz Bandwidth, 1 RB, QPSK
	Band 3	23±2	10MHz Bandwidth, 1 RB, QPSK
	Band 5	23±2	10MHz Bandwidth, 1 RB, QPSK
	Band 7	23±2	10MHz Bandwidth, 1 RB, QPSK
	Band 8	23±2	10MHz Bandwidth, 1 RB, QPSK
	Band 20	23±2	10MHz Bandwidth, 1 RB, QPSK

	Band 28	23±2	10MHz Bandwidth, 1 RB, QPSK
LTE TDD	Band 38	23±2	10MHz Bandwidth, 1 RB, QPSK
	Band 40	23±2	10MHz Bandwidth, 1 RB, QPSK
	Band 41	23±2	10MHz Bandwidth, 1 RB, QPSK

<b>EIO118-EAU-LTE Sensitivity</b>				
<b>Mode</b>	<b>Band</b>	<b>Sensitivity(dBm) PRX Typ.</b>	<b>Sensitivity(dBm) DRX Typ.</b>	<b>Note</b>
GSM	GSM 850	-109	-	BER<2.43%
	GSM 900	-109.5	-	BER<2.43%
	DCS 1800	-109	-	BER<2.43%
WCDMA	Band 1	-111	-110.5	BER<0.1%
	Band 5	-111	-110.5	BER<0.1%
	Band 8	-111	-110.5	BER<0.1%
LTE FDD	Band 1	-98.5	-99	10MHz Band width
	Band 3	-99	-99	10MHz Band width
	Band 5	-98.5	-99	10MHz Band width
	Band 7	-97	-97.5	10MHz Band width
	Band 8	-98.5	-98.5	10MHz Band width
	Band 20	-98.5	-99	10MHz Band width
	Band 28	-97.5	-99	10MHz Band width
LTE TDD	Band 38	-98	-96.5	10MHz Band width
	Band 40	-98	-97	10MHz Band width
	Band 41	-97	-96.5	10MHz Band width

### 3.1.2 EIO118-JP-LTE Operating Band, Transmission Power and Sensitivity

EIO118-JP-LTE Operating Band			
Operating Band	Description	Tx (MHz)	RxMHz)
Band 1	LTE FDD/WCDMA	1920-1980	2110-2170
Band 3	LTE FDD	1710-1785	1805-1880
Band 6	WCDMA	832.4-837.6	877.4-882.6
Band 8	LTE FDD/WCDMA	880-915	925-960
Band 11	LTE FDD	1427.9-1452.9	1475.9-1500.9
Band 18	LTE FDD	815-830	860-870
Band 19	LTE FDD/WCDMA	830-845	875-890
Band 21	LTE FDD	1447.9-1462.9	1495.9-1510.9
Band 26	LTE FDD	814-849	859-894
Band 28	LTE FDD	703-748	758-803
Band 41	LTE TDD	2535-2655	

EIO118-JP-LTE Operating Band Transmission Power			
Mode	Band	Tx Power (dBm)	Note
WCDMA	Band 1	23.5±1.5	-
	Band 6	23.5±1.5	-
	Band 8	23.5±1.5	-
	Band 19	23.5±1.5	-
LTE FDD	Band 1	23±2	10MHz Bandwidth, 1 RB
	Band 3	23±2	10MHz Bandwidth, 1 RB
	Band 8	23±2	10MHz Bandwidth, 1 RB
	Band 11	23±2	10MHz Bandwidth, 1 RB
	Band 18	23±2	10MHz Bandwidth, 1 RB
	Band 19	23±2	10MHz Bandwidth, 1 RB
	Band 21	23±2	10MHz Bandwidth, 1 RB
	Band 26	23±2	10MHz Bandwidth, 1 RB
LTE TDD	Band 41	23±2	10MHz Bandwidth, 1 RB

<b>EIO118-JP-LTE Sensitivity</b>				
<b>Mode</b>	<b>Band</b>	<b>Sensitivity(dBm) PRX Typ.</b>	<b>Sensitivity(dBm) DRX Typ.</b>	<b>Note</b>
WCDMA	Band 1	-110.5	-110.5	-
	Band 6	-111.0	-110.5	-
	Band 8	-110.5	-110.5	-
	Band 19	-111.0	-110.5	-
LTE FDD	Band 1	-98.5	-99.5	10MHz Bandwidth, 50RB
	Band 3	-98.5	-98.5	10MHz Bandwidth, 50RB
	Band 8	-98.5	-99.5	10MHz Bandwidth, 25RB,High
	Band 11	-98.0	-98.5	10MHz Bandwidth, 25RB,High
	Band 18	-99.0	-99.5	10MHz Bandwidth, 25RB,High
	Band 19	-99.0	-99.5	10MHz Bandwidth, 25RB,High
	Band 21	-98.5	-98.5	10MHz Bandwidth, 25RB,High
	Band 26	-98.5	-99.5	10MHz Bandwidth, 25RB,High
	Band 28	-99.0	-99.0	10MHz Bandwidth, 25RB,High
LTE TDD	Band 41	-97.5	-98.0	10MHz Bandwidth, 50RB

### 3.1.3 EIO118-AMATT-LTE & EIO118-AMVzW-LTE Operating Band, Transmission Power and Sensitivity

<b>EIO118-AMATT-LTE &amp; EIO118-AMVzW-LTE Operating Band</b>			
<b>Operating Band</b>	<b>Description</b>	<b>Tx (MHz)</b>	<b>Rx(MHz)</b>
Band 2	LTE FDD/WCDMA	1850- 1910	1930 - 1990
Band 4	LTE FDD/WCDMA	1710-1755	2110-2155
Band 5	LTE FDD/WCDMA	824 - 849	869 - 894
Band 12	LTE FDD	699-716	729-746
Band 13	LTE FDD	777-787	746-756
Band 17	LTE FDD	704-716	734-746
Band 66	LTE FDD	1710-1780	2110-2200
Band 71	LTE FDD	663-698	617-652

<b>EIO118-AMATT-LTE &amp; EIO118-AMVzW-LTE Transmission Power</b>			
<b>Mode</b>	<b>Band</b>	<b>Tx Power (dBm)</b>	<b>Note</b>
WCDMA	Band 2	23.5±1.5	-
	Band 4	23.5±1.5	-
	Band 5	23.5±1.5	-
LTE FDD	Band 2	23±2	10MHz Bandwidth, 1 RB
	Band 4	23±2	10MHz Bandwidth, 1 RB
	Band 5	23±2	10MHz Bandwidth, 1 RB
	Band 12	23±2	10MHz Bandwidth, 1 RB
	Band 13	23±2	10MHz Bandwidth, 1 RB
	Band 17	23±2	10MHz Bandwidth, 1 RB
	Band 66	23±2	10MHz Bandwidth, 1 RB
	Band 71	23±2	10MHz Bandwidth, 1 RB

<b>EIO118-AMATT-LTE &amp; EIO118-AMVzW-LTE Sensitivity</b>				
<b>Mode</b>	<b>Band</b>	<b>Sensitivity(dBm) PRX Typ.</b>	<b>Sensitivity(dBm) DRX Typ.</b>	<b>Note</b>
WCDMA	Band 2	-109	-	BER<0.1%
	Band 4	-109.5	-	BER<0.1%
	Band 5	-111	-	BER<0.1%
LTE FDD	Band 2	-97.8	-98.5	10MHz Band width
	Band 4	-97.8	-98	10MHz Band width
	Band 5	-99	-99.5	10MHz Band width
	Band 12	-98	-98.5	10MHz Band width
	Band 13	-97	-98	10MHz Band width
	Band 17	-97	-98	10MHz Band width
	Band 66	-97.8	-98	10MHz Band width
	Band 71	-98	-98.5	10MHz Band width

## 3.2 GNSS Receiver

The EIO118 series MiniPCIe module supports GNSS functionality and the NMEA-0183 protocol. The specifications are as follows:

<b>EIO118 series MiniPCIe module GNSS Specifications</b>			
<b>Description</b>	<b>Condition</b>	<b>Typ.</b>	<b>Note</b>
Frequency	L1 Band	1559~1609 MHz	
Power Consumption	GNSS fixing	62mA	AT+CFUN=0
	GNSS tracking	62mA	AT+CFUN=0
	Standby	34mA	AT+CFUN=0
TTFB Times	Cold start	58s	
	Warm start	50s	
	Hot Start	7.5s	
Sensitivity	Acquisition	-144dBm	
	Tracking	-155dBm	
Positional Accuracy	GNSS Signal@-130dBm	<3.5m	

### 3.3 Antenna Design Requirements

EIO118 series MiniPCle module Antenna Design Requirements				
Description	Condition	Type	Note	
GSM/UMTS/LTE	Frequency	698~2700MHz		
	VSWR	Recommended $\leq 2:1$		
	S11	Recommended $< -10\text{dB}$		
	Gain	Recommended $\leq 2.5\text{dBi}$		
	Efficiency	Recommended $> 40\%$ (-4dB)		
	Max input power		$> 33\text{dBm}$ (2 W) peak power GSM	
			$> 23\text{dBm}$ average power WCDMA & LTE & TD-SCDMA & CDMA & EVDO	
	Input impedance	50 $\Omega$		
GNSS	Passive GNSS Antenna			
	Frequency	1559~1609 MHz		
	Polarization	RHCP or linear		
	Input impedance	50 $\Omega$		
	VSWR	Recommended $\leq 2:1$		
	Passive Antenna Gain	Recommended $> 0\text{dBi}$		
Active GNSS antenna	Frequency	1559~1609 MHz		
	Polarization	RHCP or linear		
	Input impedance	50 $\Omega$		
	VSWR	Recommended $\leq 2:1$		
	Noise Figure	Recommended $< 1.5\text{dB}$		
	Active antenna gain	Recommended $> 0\text{dBi}$		
	Active antenna LNA gain	Recommended $< 17\text{dB}$		



**Note:** Interference

- In addition to antenna performance, other interferences on the PCB also affect the performance of the module. To ensure high performance of the module, interference must be controlled.  
Suggestions: For example, LCDs, CPUs, FPC cables, audio circuits, power supplies should be kept as far away from the antenna as possible, with appropriate isolation, shielding, or filtering applied where necessary.
- It is recommended to use a passive GNSS antenna for the EIO118 series MiniPCle module when LTE B13 or B14 is supported, as the use of an active antenna may generate harmonics that affect GNSS performance.
- Since the GNSS port has a 3.3 V voltage output, PIFA type passive antenna that causes short to GND, is not recommended!

### 3.4 Antenna RF Connector

The EIO118 series MiniPCle module provides three RF connectors. It is recommended that the application uses a matching RF adapter cable. MAIN is the RF main antenna interface, DIV is the diversity antenna interface, and GNSS is the GNSS antenna interface.

The RF connector of the EIO118 series MiniPCle module uses the HIROSE U.FL-R-SMT-1(XX) Series

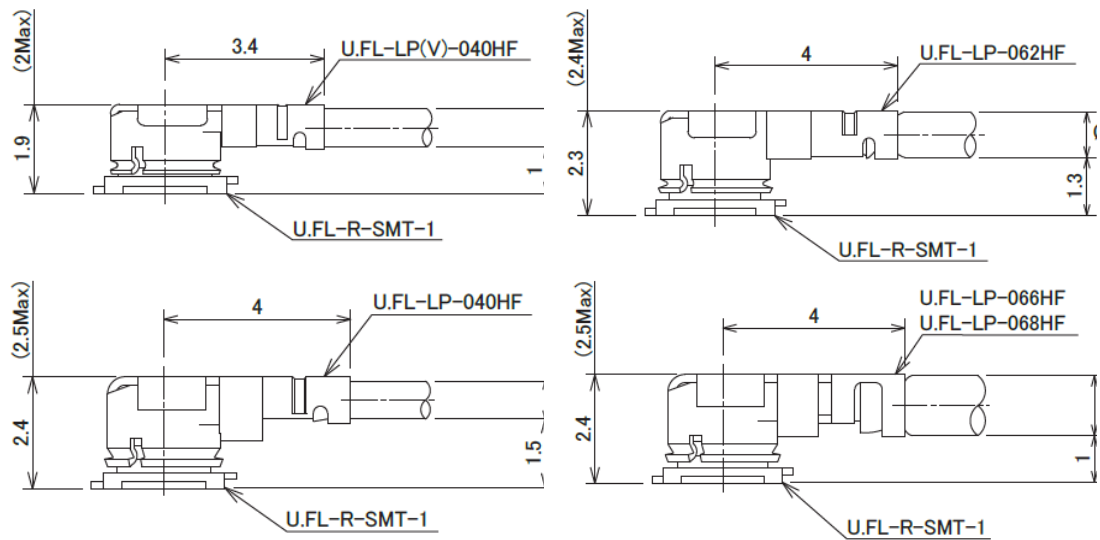
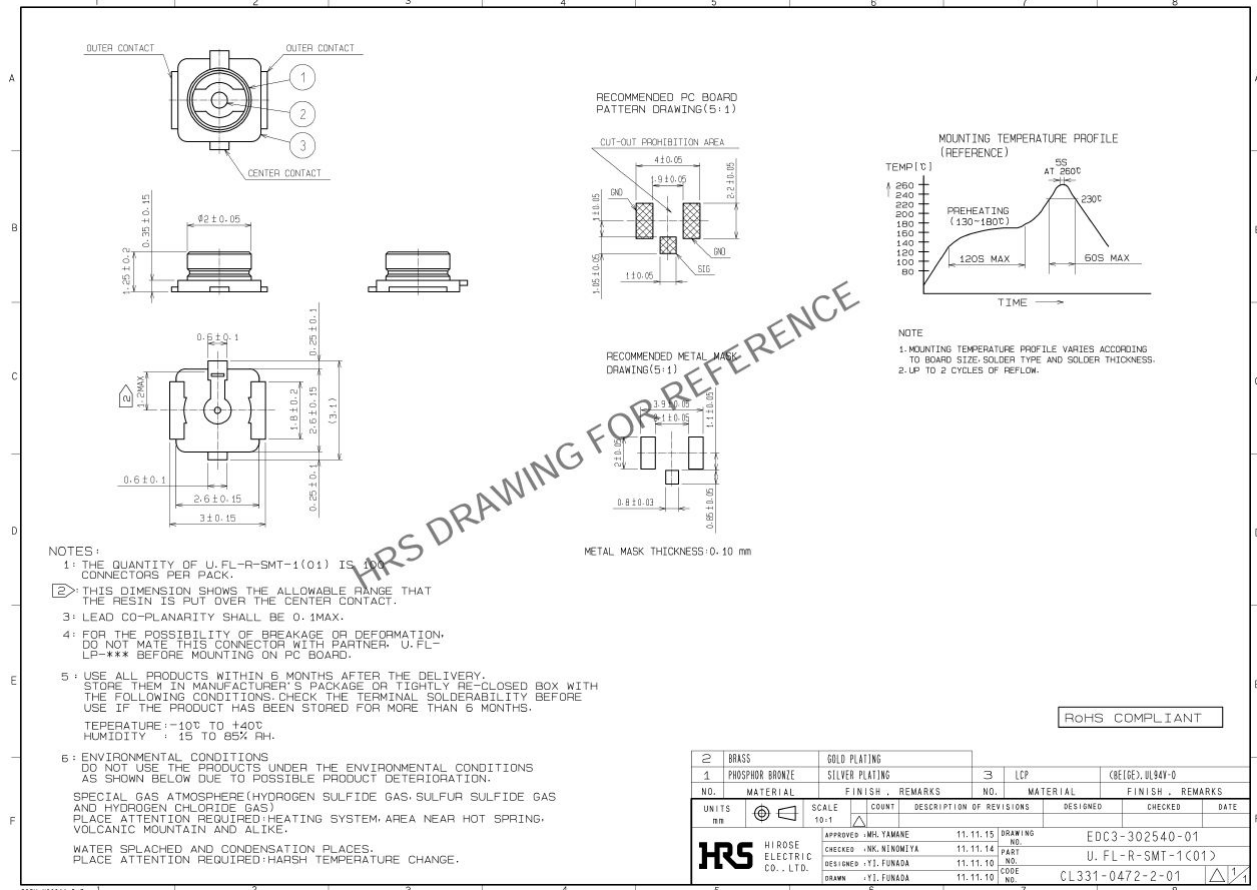

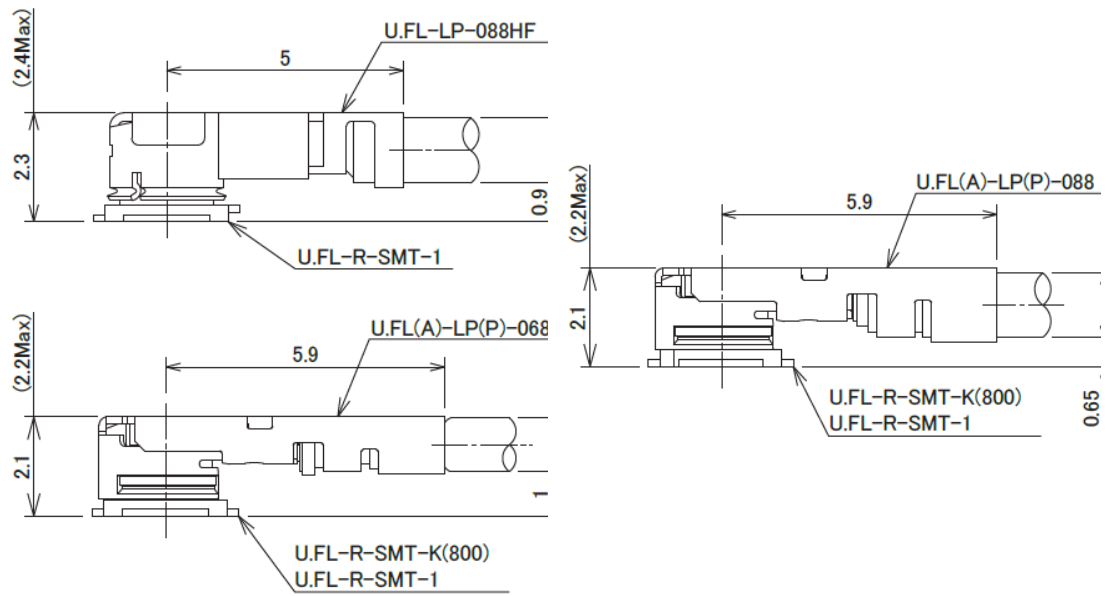

# Section 4

## Structure Dimensions Specification

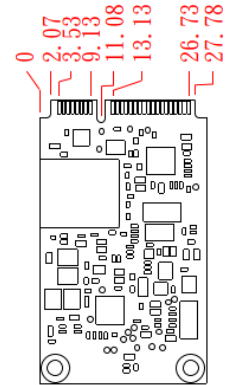
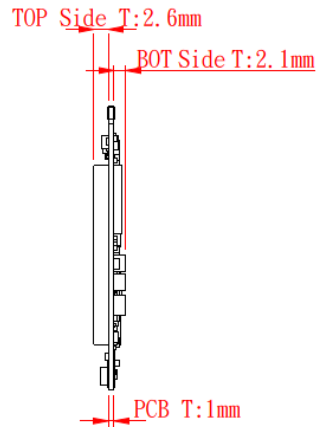
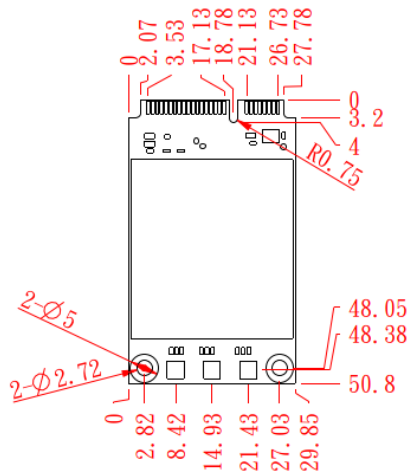
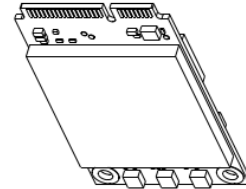
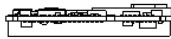

**This page is intentionally left blank.**

# Section 5

## EIO118 MCU Commands List

The EIO118 has a built-in MCU and can monitor the module's internal operating status and provide simple control through the UART interface.

### 5.1 EIO118 MCU Control Interface

The control function uses the UART port on the MCU. The UART port PID number is 08FC, and the VID number is 118B.

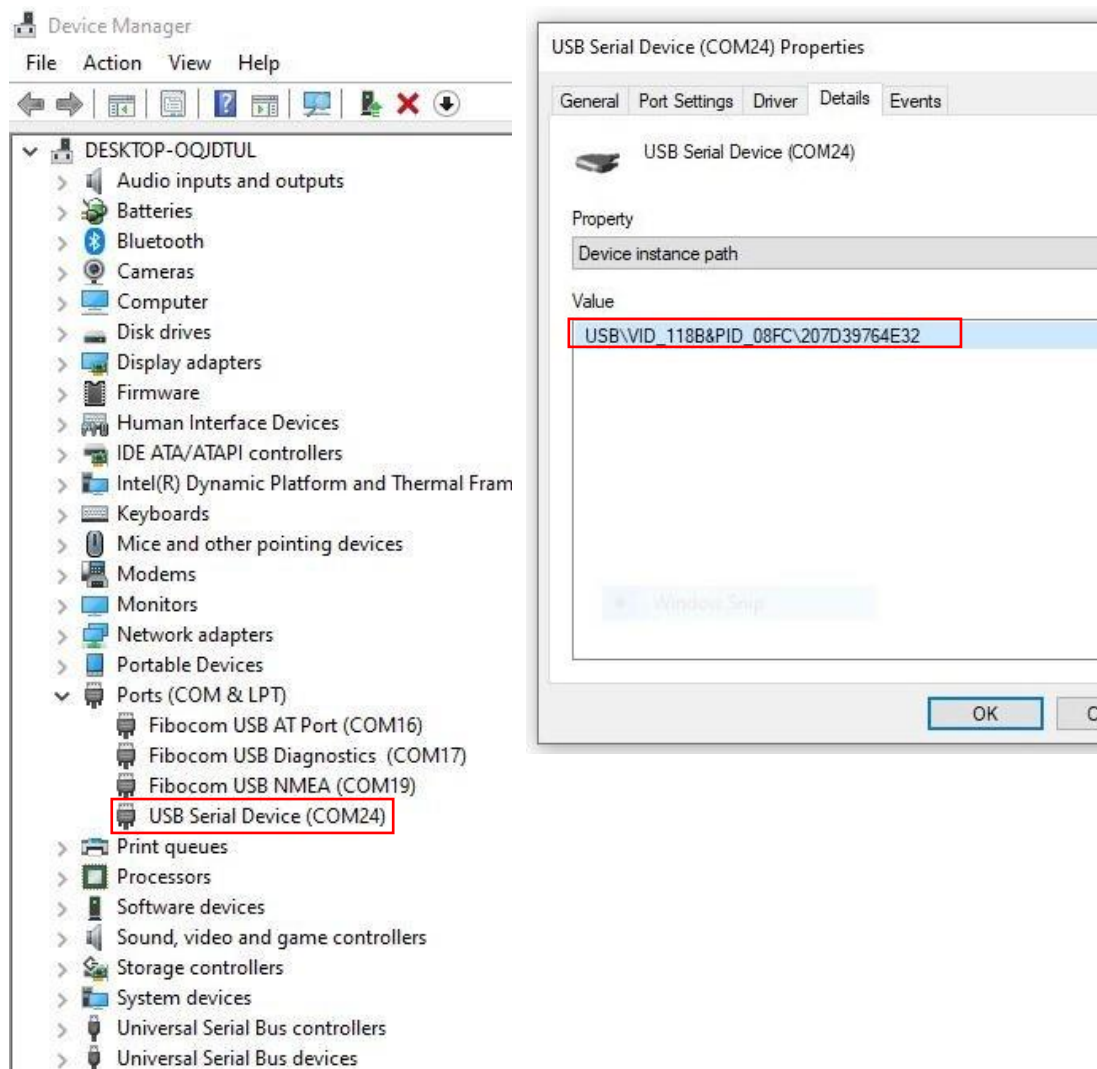

Windows Device Management

UART Port PID & VID number

## 5.2 EIO118 MCU Commands List

The MCU has built-in watchdog and power sequence management functions on the module. Please refer to the MCU-supported command list;

Item	Description	Command	Response from EIO118 MCU
1	All Command List	CMD_LIST	>OK > 1. HRST > 2. SIM_MB > 3. SIM_MODULE > 4. STATES > 5. HISTORY > 6. READ_CHKBYTE > 7. SHOW_TIME > 8. LIST > 9. DBG+ON > 10. DUMP_EEPROM > 11. MCU_RST >Finish
2	EIO118 Module Hardware reset	CMD_HRST	>OK >Turn off the power of LTE module >Turn on the power of LTE module >Reset LTE module >Finish
3	Switch the SIM Card interface to the Main Board	CMD_SIM_MB	>OK >Turn off the power of LTE module >Turn on the power of LTE module >Reset LTE module >Finish
4	Switch the SIM Card interface to the Module	CMD_SIM_MODULE	>OK >SIM slot will change to module side >Turn off the power of LTE module >SIM slot ----> Module >Turn on the power of LTE module >Reset LTE module >Finish
5	Real time Module status	CMD_STATES	>OK ===== =====

			<p>Immediate DATA</p> <p>&gt;MCU FW VER = 24042302</p> <p>&gt;Module Health = Good</p> <p>&gt;SIM slot use main board side</p> <p>&gt;Real time Temperature = ***C</p> <p>&gt;Voltage = ***mV</p> <p>&gt;Current = ***mA</p> <p>&gt;Power = ***W</p> <p>&gt;Max Voltage = ***mV</p> <p>&gt;Min Voltage = ***mV</p> <p>&gt;Max Current = ***mA</p> <p>=====</p> <p>=====</p> <p>&gt;Finish</p>
6	Module states EEPROM record at	CMD_HISTORY	<p>*****</p> <p>&gt;EEPROM DATA</p> <p>&gt;Max Voltage Record = ***mV</p> <p>&gt;Min Voltage Record = ***mV</p> <p>&gt;Max Current Record = ***mA</p> <p>&gt;Max Temperature Record = ***C</p> <p>&gt;Over Current Times Record = ***</p> <p>&gt;Under Voltage Times Record = ***</p> <p>&gt;Used Times = *** Years - *** days - *** Hours - *** minutes - *** seconds</p> <p>*****</p> <p>&gt;Finish</p>
7	Check EEPROM empty status	CMD_READ_CHKBYTE	<p>&gt;OK</p> <p>&gt;Check Byte = 204</p> <p>&gt;Finish</p>
8	Read Module used time	CMD_SHOW_TIME	<p>&gt;OK</p> <p>&gt;Ref Timer = **:**.:**</p> <p>&gt;Used times = *** Years - *** days - *** Hours - *** minutes - *** seconds</p> <p>&gt;Finish</p>
9	Turn on the Module debug message output	CMD_DBG+ON	<p>&gt;OK</p> <p>&gt;Debug message is turn on</p> <p>&gt;Finish</p>
10	Turn on the Module	CMD_DBG+OFF	<p>&gt;OK</p>

	debug message output		>Debug message is turn off >Finish
11	Reset MCU	CMD_MCU_RST	>OK >! MCU will reset now >Finish