

GOT-5840T-830

8.4" SVGA TFT Fanless Touch Panel Computer with Intel® Atom™ Processor N270

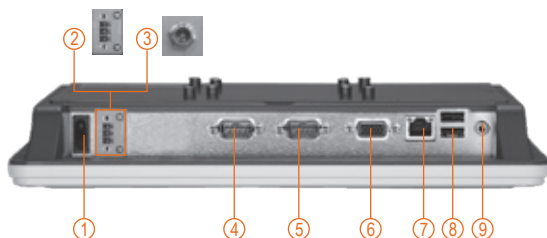

- | | |
|---|---------------------|
| 1. Power switch (ATX) | 6. VGA |
| 2. Terminal block for DC power input
or 3. Screw conn. w/ AC power adapter | 7. Ethernet |
| 4. COM 1 (RS-232/422/485) | 8. USB 2.0 x 2 |
| 5. COM 2 (RS-232) | 9. Audio (Line-out) |

Features



Fanless Low Power DualView

- 8.4" SVGA (800 x 600) color TFT LCD display
- Fanless cooling system with Intel® Atom™ processor N270 1.6 GHz
- Ultra Slim design: thickness 45mm
- Super light weight: 1.3 kg
- Easy for expansion: Mini card
- Supports panel mount, wall mount, VESA arm, desktop stand (optional)
- RFID (optional)
- Over-current protection fuse



Side view



Desktop stand

Introduction

The GOT-5840T-830 is a 8.4" Intel® Atom™-based fanless touch panel computer. In response to market demand, this panel computer is a cost effective solution. It adopts a modern, super sleek and fanless design and is equipped with a 8.4" TFT LCD as well as Intel® Atom™ processor N270 1.6 GHz. For wireless network connection, the GOT-5840T-830 offers a mini card slot. By just plugging in the mini card WLAN card, customers can have instant access to wireless LAN/GPRS/GSM/3G environments. Besides, it provides two types of power input. One is DC power input (10-30VDC) with terminal block connector. The other is AC power adapter with screw type connector.

Super slim & ultra light design

The GOT-5840T-830 is a super slim touch panel computer for space-limited environment with its thickness of 45mm and weight of 1.3 kg only, which make it

installed everywhere.

Built-in internal WLAN antenna

The GOT-5840T-830 provides a mini card slot and a built-in WLAN antenna for wireless network connections. By simply plugging in the wireless LAN card, customers can use the GOT-5840T-830 in a wireless LAN/GPRS/GSM/3G environments.

Excellent thermo solution: aluminum back chassis

With Axiomtek's patent for plastic plus aluminum mechanism design, the GOT-5840T-830 can dissipate the heat easily and keep the system operation stable.

Specifications

Front Bezel	IP65, NEMA 4 rugged protection, plastic front bezel		System Memory	1 x 200-pin DDR2 SODIMM max. up to 2 GB
LCD Panel	Display Type	8.4" SVGA TFT LCD	BIOS	AMI 8 Mbit with RPL/PXE LAN boot ROM
	Brightness (cd/m ²)	250 nits	Storage	1 x CompactFlash™
	Resolution	800 x 600	Watchdog	255 levels, 0-255 sec.
	Viewing Angel (H/V)	160° / 140°	Timer	
Main System	CPU	Intel® Atom™ processor N270 1.6 GHz	Onboard Graphics	Integrated in Intel® 945GSE
	Chipset	Intel® 945GSE + ICH7M		

I/O Connector	1 x RS-232 (COM 2) 1 x RS-232/422/485 (COM 1) 2 x USB2.0 1 x 10/100/1000Mbps Ethernet 1 x Audio (Line-out) 1 x VGA
Expansion Interface	1 x PCIe Mini Card
Touchscreen	Resistive type
Power Input	1. DC version: 10-30VDC with over-current protection fuse 2. AC version: 100-240V AC-DC 60W power adapter
Dimensions	250.7 mm (9.87") (W) x 45.8 mm (1.80") (D) x 204.7 mm (8.06") (H)
Weight (net/gross)	1.3 kg (2.87 lb)/2.25 kg (4.96 lb)
Environment	Operating temperature: 0°C - +50°C (32°F - 122°F) (with W.T. DRAM/HDD in airflow condition) 0°C - +45°C (32°F - 113°F) (with W.T. DRAM) Relative humidity: 10% - 95% @ 40°C; non-condensing Operation vibration: 2G, 5-500Hz, random for CompactFlash™
Certification	CE-EMC Class A: GOT-5840T-830 CE-EMC Class B: GOT-5840T-830-J

* W.T.: Wide Temperature. All W.T. supported products have to be sorted by Axiomtek.

Dimensions

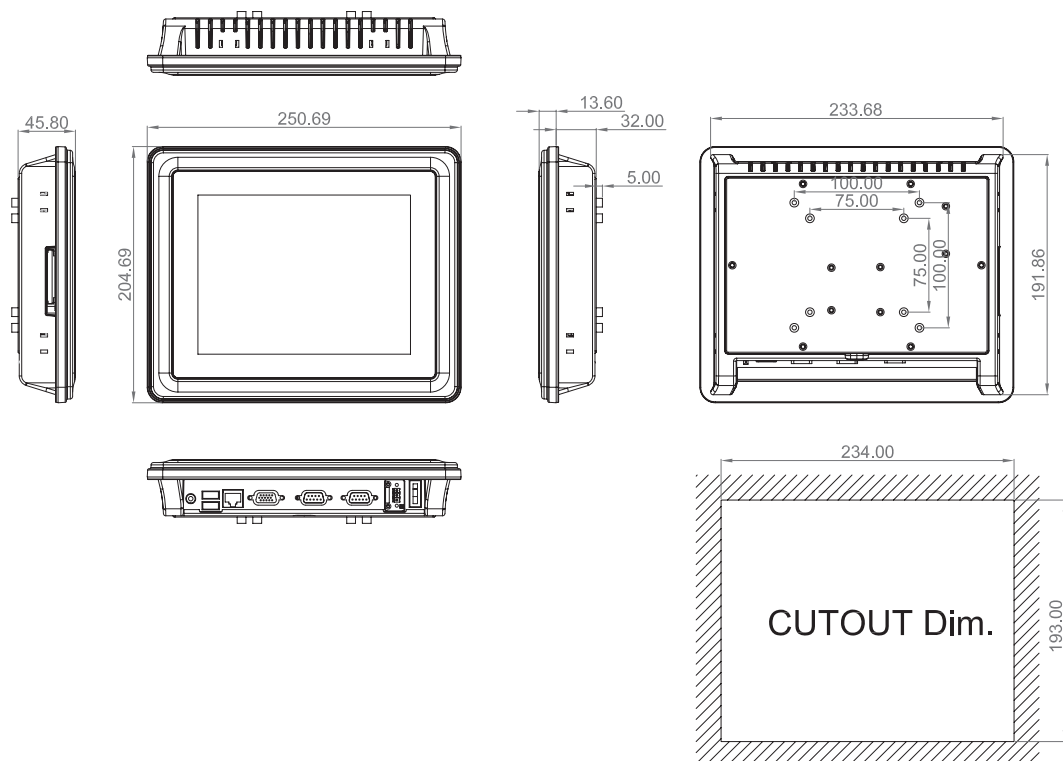

Ordering Information

GOT-5840T-830	8.4" Intel® Atom™ N270 fanless touch panel computer with terminal block connector
GOT-5840T-830-J	8.4" Intel® Atom™ N270 fanless touch panel computer with screw type connector & AC-DC 60W power adapter
E225840102	Desktop stand
Wireless kit	802.11 b/g wireless LAN kit

* Specification and certifications are based on options and may vary.

Optional EOS Installation

Windows® CE.NET
Windows® XP Embedded

Optional OS Installation

Windows® XP



AC power adapter
(for GOT-5840T-830-J)

Touch Panel Computers for Various Industry Applications

Digital Signage and Display Solutions

Medical Panel Computers

Medical Grade Monitors

GOT Fanless Touch Panel Computers

Touch Panel Computers for Infotainment

Touch Panel Computers for Automation

Touch Panel Monitors for Automation

Open Frame Panel Computers

Accessories