

# IFO2175-830-FL

17" TFT Fanless Touch Panel Computer with Intel® Atom™ Processor N270

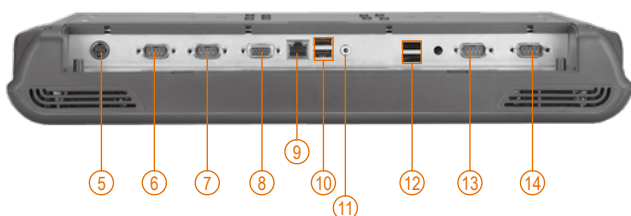

## Features

- 17" high brightness (380 nits) SXGA TFT LCD
- Intel® Atom™ processor N270 1.6 GHz
- Water/dust-proof design (front bezel: IP65, full enclosure: IPX1)
- Fanless and noiseless operation
- Optional 1.3 mega pixels camera
- Optional Bluetooth/internal WiFi (802.11 b/g)

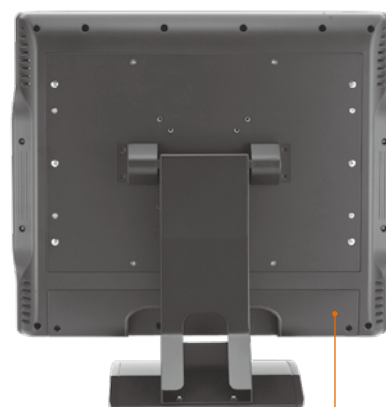

I/O cover

- |                              |                           |                      |
|------------------------------|---------------------------|----------------------|
| 1. Brightness adjust buttons | 5. Power connector        | 10. USB 2.0 x 2      |
| 2. Volume adjust buttons     | 6. COM 1 (RS-232/422/485) | 11. Audio (Line-out) |
| 3. Power LED                 | 7. COM 2 (RS-232)         | 12. USB 2.0 x2       |
| 4. Power switch              | 8. VGA                    | 13. COM 3 (RS-232)   |
|                              | 9. Ethernet               | 14. COM 4 (RS-232)   |

## Introduction

The IFO2175-830-FL is a slim panel computer equipped with a 17-inch 380 nits SXGA LCD display and supports superior Intel® Atom™ processor N270. Powered by Intel® 945GSE+ICH7M core logic chipset with maximum 256 MB sharing graphics memory, this panel computer has better graphics performance. The panel computer also supports DualView and multiple I/O options including 4 USB 2.0, and 4 RS-232 ports. The built-in 1.3 mega pixels camera and speakers can provide a solution for VoIP and remote monitoring. The IFO2175-830-FL also supports an antenna for 802.11b/g wireless connectivity. The Gigabit Ethernet port can provide superior high speed of Ethernet. It features low noise, low power

consumption, high reliability and high performance. Its excellent industrial design (ID) and user friendly interface design make the IFO2175-830 safe, reliable & user-friendly panel computer. Best suited for infotainment, media content display and DSA solutions.

### Water/dust-proof design for entire system: IPX1

The IPX1-rated water/dust-proof housing protects the entire system from outside damage of water drip in public maintenance and re-installation place. This unique design improves system stability and save maintenance and re-installation time.

## Specifications

Front Bezel	Plastic ABS (Black)		BIOS	AMI BIOS with SmartView and customer CMOS backup
LCD Panel	Display Type	17" SXGA TFT	Storage	1 x 2.5" SATA HDD (optional)
	Brightness (cd/m <sup>2</sup> )	380 nits		1 x CompactFlash™
	Resolution	1280 x 1024	Optical Drive	1 x combo drive (optional)
	Viewing Angle (H/V)	160° / 160°	Watchdog	255 levels, 1-255 sec.
Main System	CPU	Intel® Atom™ processor N270 1.6 GHz	Timer	
	Chipset	Integrated in Intel® 945GSE + ICH7M	Onboard	Integrated in Intel® 945GSE; max. memory shared 256 MB
	System Memory	1 x DDR2 SO-DIMM max. up to 2 GB	Graphics	

I/O Connector	3 x RS-232 (COM 2/3/4) 1 x RS-232/422/485 (COM 1) 4 x USB 2.0 1 x Audio (Line-out) 1 x VGA 1 x 10/100/1000Mbps Ethernet
Expansion Interface	1 x Mini card slot
Camera	1 x 1.3 mega pixels camera
Touchscreen	Resistive type
Power Supply	12V <sub>dc</sub> with AC-DC power adaptor
Dimensions	437.98 mm (17.24") (W) x 68.5 mm (2.7") (D) x 376.41 mm (14.82") (H)
Weight (net/gross)	7.65 kg (16.85 lb)/9 kg (19.84 lb)
Environment	Operating temperature: 0° C ~ +40° C (32° F ~ 104° F) Relative humidity: 10% ~ 95%, non-condensing
Certification	CE

## Ordering Information

IFO2175-830-FL with combo	17" TFT high brightness fanless panel computer with Intel® Atom™ N270, resistive T/S, slim combo and camera
IFO2175-830-FL w/o combo	17" TFT high brightness fanless panel computer with Intel® Atom™ N270, resistive T/S (w/o combo and camera)

\* Specification and certifications are based on options and may vary.

## Dimensions

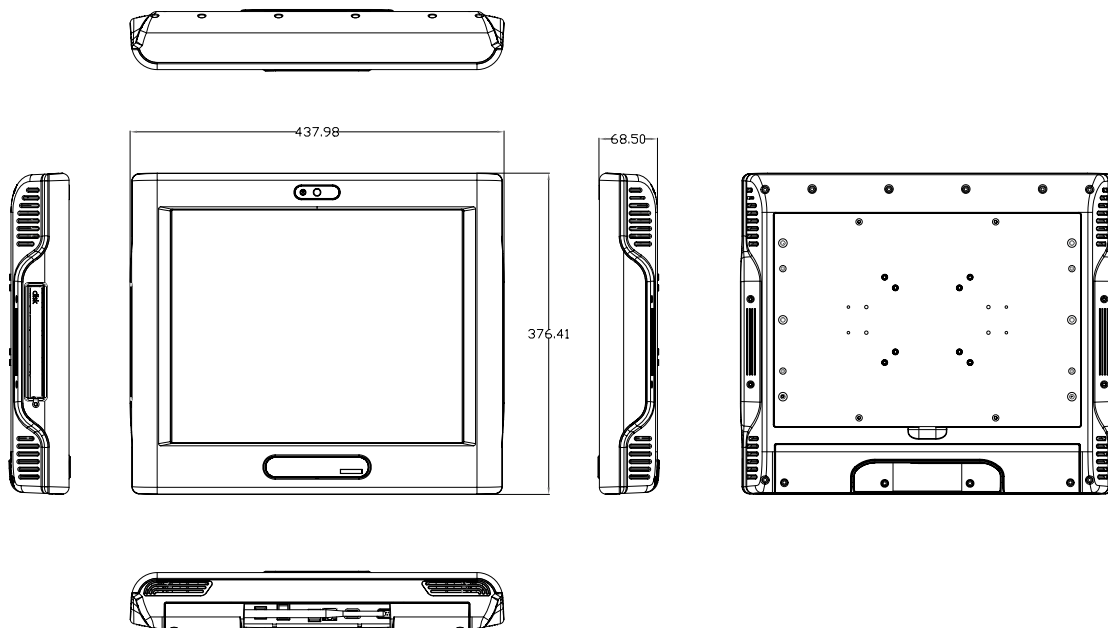

## Optional Accessories

E202003330	VM-101 VESA ARM (clamp type)
E202003329	VM-105 VESA ARM (wall mount type)
E222175103	17" stand kit

## Optional EOS Installation

Windows® XP Embedded

## Optional OS Installation

Windows® XP

Windows® 7

Overview

Digital Signage Solutions

Healthcare & Medical Solutions  
Medical Panel Computers

Healthcare & Medical Solutions  
Medical Grade Monitors

Fanless & Heavy-duty Touch Panel Computers

Touch Panel Computers for Infotainment

Industrial Touch Panel Computers & Monitors  
Industrial Touch Panel Computers

Industrial Touch Panel Computers & Monitors  
Industrial Touch Panel Monitors

Open Frame Panel Computers

Accessories